



# Falk™ Lifelign™ Gear Couplings

IMPERIAL





# TABLE OF CONTENTS

---

DESCRIPTION	PAGE
Falk™ Lifelign™ Gear Coupling Application Guide .....	4
How to Select .....	6
Quick Selection Method .....	8
Service Factors .....	10
How to Order .....	12
Products .....	12
<b>STANDARD FLANGED SLEEVE GEAR COUPLINGS</b>	
Type G20 Standard Flanged Sleeve Double Engagement .....	13
Type G32 Standard Flanged Sleeve Spacer .....	14
Type G52 Standard Flanged Sleeve Single Engagement .....	15
Type GV20 Standard Flanged Sleeve Vertical Double Engagement .....	18
Type GV52 Standard Flanged Sleeve Vertical Single Engagement .....	19
Types G62, G63, G66 & G67 Standard Flanged Sleeve Brakewheel/Disc Brake .....	20
Type GL20 Standard Flanged Sleeve Slide Double Engagement .....	21
Type GL32-1 Standard Flanged Sleeve Spacer Slide Single Engagement .....	22
Type GL52 Standard Flanged Sleeve Slide Single Engagement .....	23
Type G70 Disconnect (Inching Drives) .....	24
Type G72 Disconnect .....	25
Type G82 Standard Flanged Sleeve Rigid .....	26
Type GV82 Standard Flanged Sleeve Rigid Thrust .....	27
<b>LARGE FLANGED SLEEVE GEAR COUPLINGS</b>	
Type G20 Large Flanged Sleeve Double Engagement .....	28
Type G52 Large Flanged Sleeve Single Engagement .....	29
Type GV20 Large Flanged Sleeve Vertical Double Engagement .....	31
Type GV52 Large Flanged Sleeve Vertical Single Engagement .....	32
Type GL20-4 Large Flanged Sleeve Slide Double Engagement .....	33
Type G70 Large Disconnect .....	34
Type G82 Large Flanged Sleeve Rigid .....	35
<b>TECHNICAL DATA</b>	
Type G Standard Flanged Sleeve Mill Motor & Taper Bores .....	36
Engineering Data — Standard Flanged Sleeve .....	37
Engineering Data — Large Flanged Sleeve .....	42
Engineering Data — All Gear Couplings .....	47
Lifelign Gear Coupling Nomenclature .....	49
Coupling Application Data Sheet .....	50

# FALK™ LIFELIGN™ GEAR COUPLING APPLICATION GUIDE

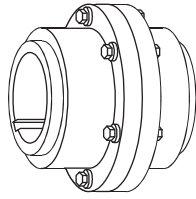

Types G20, GV20

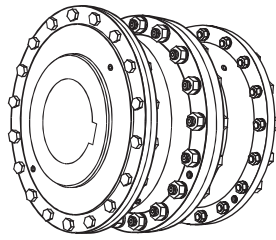

Type G Large Gear Coupling

The Type G20 double engagement, close-coupled type has two flex halves to accommodate both offset and angular misalignment or a combination of the two, as well as end float. It is ideal for all horizontal, close-coupled applications including fans, overhead cranes, conveyors, steel and paper mill equipment. It is adaptable with limited end float kits for use on electric motors, generators or any machines fitted with sleeve or straight roller bearings. (See **page 13**.)

Type GV20 vertical double engagement coupling is a standard horizontal double engagement gear coupling modified to accommodate the sleeve-centering assembly. Recommended for inclinations over 10°. (See **pages 18 and 19**.)

The Type G Large Gear Coupling is available in all types for capacities up to 72,450,000 lb-in, 8,185,000 Nm. (See **page 28**.)

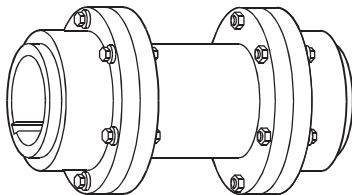

Types G32

Spacer couplings for pump and compressor applications simplify servicing connected equipment. Spacer couplings use a standard double engagement coupling with a spacer tube and an additional set of fasteners. Stock spacer lengths for quick delivery are available in the popular sizes. Special lengths are also available. (See **page 14**.)

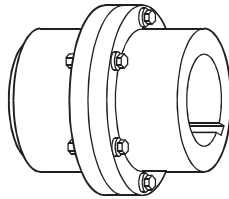

Type G52

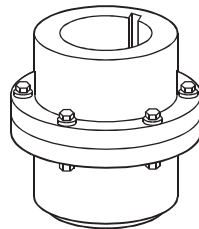

Type GV52

The Type G52 single engagement design is used with floating shafts or three bearing drive trains. It has one flex half and one rigid half and only accepts angular misalignment. (See **pages 15-17**.)

The GV52 vertical single engagement gear coupling is a standard horizontal single engagement gear coupling modified to accommodate the sleeve-centering assembly. It is recommended for inclinations over 10°. Downward thrust capacity for Sizes 1010 thru 1030GV52 is 10,000 lbs.; for Sizes 1035 thru 1070GV52, it is 30,000 lbs. and for Sizes 1080GV52 and larger, it is 87,000 lbs. (See **page 19**.)

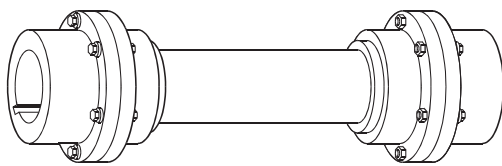

Type G52

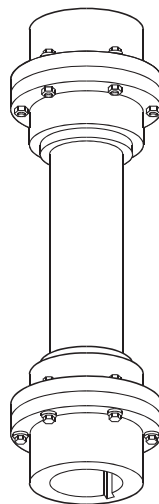

Type GV52

Floating shaft assemblies are used when the distance between equipment is too great for spacer couplings. A standard floating shaft assembly consists of two standard single engagement couplings, two gap discs and a connecting shaft. A floating shaft can eliminate the need for additional bearing supports along spanning shafts, because the shaft is supported by connected equipment through the single engagement couplings. (See **pages 16-18**.) When used with a vertical floating shaft on inclinations over 10°, the Type GV52 coupling is used as the lower coupling to support the shaft. (See **page 19**.)

Flex Hubs on Floating Shaft (RFFR) — Assembly of the flex hubs on the floating shaft allows for easier replacement and allows the rigid hubs with greater bore capacity to be used on the connected equipment shafts. This frequently means a smaller coupling size can be utilized.

Rigid Hubs on Floating Shaft (FRRF) — When the rigid hubs are on the floating shaft, shorter shaft spans can be accommodated, since no cover drawback is required.

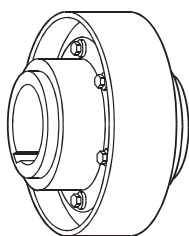

Types G62 & G66

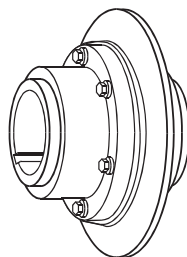

Type G63 & G67

Double or single engagement brakewheel and disc brake couplings are used for applications such as cranes, hoists and conveyors. Brakewheel and disc brake couplings accommodate misalignment between connected equipment and eliminate the need for double shaft extensions on motors and gear drives for applications requiring brakes. (See **page 20**.)

# FALK™ LIFELIGN™ GEAR COUPLING APPLICATION GUIDE

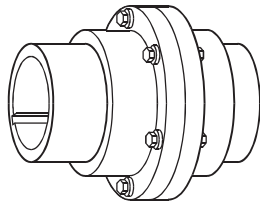

Types GL20 & GL52

Double and single engagement slide couplings are used for applications requiring axial movement to accommodate thermal shaft expansion or adjustment. (See **pages 21 and 23.**)

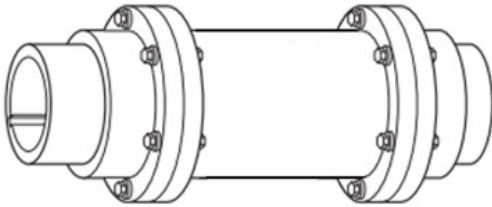

GL32-1

Spacer slide couplings are used for adjustable (impellar) pumps and applications requiring axial movement to accommodate thermal shaft expansion or adjustment. Spacer slide couplings use GL20 double engagement components with a spacer tube, spacer plates and an additional set of fasteners.

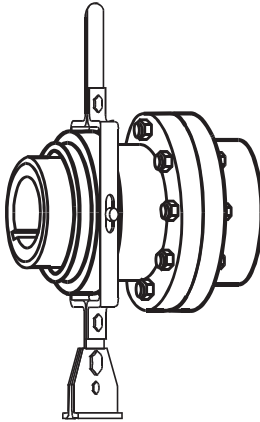

Types G70 & G72

Type G70 disconnect couplings are used for low-speed applications that require quick disconnect of equipment or inching drives. It is used for occasional servicing or inspection of drive system components and is most commonly used on portable or stationary inching drive systems where the driving end hub/sleeve combination is mounted on the driving shaft on the incher for connecting or disconnecting at standstill. (See **pages 24 and 25.**)

Type G72 disconnect couplings were designed for higher speed applications that require quick disconnect such as backup drives. When the long flex hub is mounted on the auxiliary driving shaft, the changeover is performed at standstill by engaging the free-running hub. (See **page 25.**)

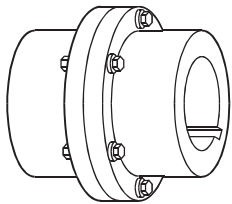

Type G82

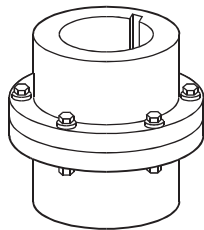

Type GV82

Rigid couplings are used when there is no need to accommodate misalignment, and where thrust loads are generated, such as vertical mixer applications. (See **pages 26 and 27.**)

# HOW TO SELECT

## Standard Selection Method

The standard selection method can be used for most motor, turbine or engine-driven applications. The following information is required to select a gear coupling:

- Horsepower or torque.
- Running rpm.
- Application or type of equipment to be connected (motor to pump, gear drive to conveyor, etc.).
- Shaft diameters.
- Shaft gaps.
- Physical space limitations.
- Special bore or finish information and type of fit.

**Exceptions are high peak loads, brake applications or high frequency axial sliding (greater than 5 per hour). For these conditions, use the Formula Selection Method on the next page. Applications that require rapid changes in direction or torque reversals should be referred to the Factory.**

1. **Rating:** Determine system torque. If torque is not given, calculate as shown below:

$$\text{System Torque (lb-in)} = \frac{\text{HP} \times 63,000}{\text{RPM}}$$

Where: HP (Horsepower) is the actual or transmitted power required by the application (if unknown, use the motor or turbine nameplate rating) and RPM is the actual speed the coupling is rotating.

2. **Service Factor:** Determine the appropriate service factor from **Tables 4 and 5**, or **Table 6**.
3. **Required Minimum Coupling Rating:** Determine the required minimum coupling rating as shown below:  
Minimum Coupling Rating = S.F. (Service Factor) x Torque (lb-in)
4. **Type:** Refer to **pages 3-13** and select the appropriate coupling type.
5. **Size:** Determine proper size of type selected from **Table 1** by tracing down the torque column to a value that is equal or greater than that determined in Step 3 above. Then turn to the dimension pages of the appropriate coupling type selected and check the following for the size selected.
6. **Check:** Coupling capacities and dimensions.
  - E. Bores — Check shaft diameters against coupling maximum bore. If bore is inadequate, consider the use of a reduced key from engineering tables, or select a larger size coupling.
  - F. Speeds (rpm) — Check the operating rpm against the coupling allowable speed. If cataloged values are inadequate, consider balancing. Balancing may allow up to a 50% increase in the speeds shown. Contact the Factory with complete application details. Check I & M manual or Factory for minimum speed recommendation for NLGI1 greases like LTG.
  - G. Dimensions — Checks are: length of hubs and alignment clearances against shaft lengths, outside diameter of coupling against radial clearances.

## Standard Selection Example:

Select a gear coupling to connect a 500 hp, 1170 rpm electric motor to a drive high-speed shaft of a maneuvering winch. Maximum shaft separation is 0.250". Motor shaft diameter is 3.375" and keyway is 0.875" x 0.438". Winch shaft diameter is 3.000" and keyway is 0.750" x 0.375". Motor and winch extensions are both 6.000" long.

1. **Determine Required Rating:**

$$\text{System Torque (lb-in)} = \frac{500 \text{ HP} \times 63,000}{1170 \text{ RPM}} = 26,923$$

2. **Service Factor:** From Service Factor **Table 4** = 1.5.

3. **Required Minimum Coupling Rating:**

$$1.5 \times 26,923 \text{ lb-in} = 40,385 \text{ lb-in}$$

4. **Type:** From **page 4**, to connect close-coupled shafts (0.250" gap) the double engagement Type 1025G20 coupling is the selection. Refer to **page 13** for dimensions.
5. **Size:** From **page 13**, a Size 1025G20 is the proper selection based on a torque rating of 66,150 lb-in exceeding the required minimum coupling rating of 40,385 lb-in.
6. **Check:** Maximum speed capacity of 5000 (1025G20) rpm exceeds required speed of 1170 rpm. Maximum bore capacity of 3.625" exceeds the actual shaft diameters.

**Table 1 — Torque and Horsepower Ratings**

Coupling Size	Torque Rating (lb-in)	HP per 100 RPM
1010G	10,080	16
1015G	20,790	33
1020G	37,800	60
1025G	66,150	105
1030G	107,100	170
1035G	163,800	260
1040G	270,900	430
1045G	371,700	590
1050G	500,900	795
1055G	655,200	1,040
1060G	800,100	1,270
1070G	1,197,000	1,900

Coupling Size		Torque Rating (lb-in – millions)		HP per 100 RPM	
		1000 Series	2000 Series	1000 Series	2000 Series
1080G	2080G	1.506	2.070	2,390	3,285
1090G	2090G	1.997	2.791	3,170	4,430
1100G	2100G	2.747	3.919	4,360	6,220
1110G	2110G	3.654	5.393	5,800	8,560
1120G	2120G	4.914	6.880	7,800	10,920
1130G	2130G	6.363	8.190	10,100	13,000
1140G	2140G	8.064	10.080	12,800	16,000
1150G	2150G	9.702	11.970	15,400	19,000
1160G	2160G	11.592	14.490	18,400	23,000
1180G	2180G	14.679	18.900	23,300	30,000
1200G	2200G	18.963	25.200	30,100	40,000
1220G	2220G	24.066	31.500	38,200	50,000
1240G	2240G	30.744	39.690	48,800	63,000
1260G	2260G	39.753	48.510	63,100	77,000
1280G	2280G	51.660	59.850	82,000	95,000
1300G	2300G	59.850	72.450	95,000	115,000

## Formula Selection Method

The Standard Selection Method can be used for most coupling selections. The procedure below should be used for:

- High Peak Loads
- Brake Applications (Where the disc brake or brakewheel is to be an integral part of the coupling, consult the Factory for design options.)
- High Frequency Axial Sliding
- Shear Pin Couplings

Providing system peak torque and frequency, duty cycle and brake torque rating will allow for a more refined selection using the Formula Selection Method.

1. **High Peak Loads:** Use one of the following formulas for applications using motors with torque characteristics that are higher than normal; applications with intermittent operations, shock loading, inertia effects due to starting and stopping and or system-induced repetitive high peak torques. System Peak Torque is the maximum torque that can exist in the system. Select a coupling with a torque rating equal to or greater than selection torque calculated below.

A. Non-Reversing High Peak Torque

Selection Torque (lb-in) = System Peak Torque

or

$$\text{Selection Torque (lb-in)} = \frac{\text{System Peak HP} \times 63,000}{\text{RPM}}$$

B. Reversing High Peak Torque

Selection Torque (lb-in) = 1.5 x System Peak Torque

or

$$\text{Selection Torque (lb-in)} = \frac{1.5 \times \text{Peak HP} \times 63,000}{\text{RPM}}$$

C. Occasional Peak Torques (Non-reversing) — If a system peak torque occurs less than 1000 times during the expected coupling life, use the following formula:

Selection torque (lb-in) = 0.5 x System Peak Torque

or

$$\text{Selection Torque (lb-in)} = \frac{0.5 \times \text{Peak HP} \times 63,000}{\text{RPM}}$$

For reversing service, select per Step B, above.

2. **Brake Applications:** If the torque rating of the brake exceeds the motor torque, use the brake rating as follows:

Selection Torque (lb-in) = Brake Torque Rating x S.F.

3. **High Frequency Axial Sliding:** For Type GL coupling, if axial movement occurs more than 5 times per hour, add 0.25 to the service factor.

$$\text{Selection Torque (lb-in)} = \frac{\text{HP} \times 63,000 \times (\text{S.F.} + 0.25)}{\text{RPM}}$$

The user-provided shear torque value must be based on a system analysis. It is recommended that the shear torque value be at least 225% of the normal transmitted torque value for non-reversing applications to avoid breaking the shear pins due to fatigue during motor start-up. For reversing applications, the recommended shear torque setting is 300-400% of normal torque to avoid fatigue failures. If the connected equipment cannot tolerate these torque levels, expect to replace the shear pins more frequently.

### Formula Selection Example — High Peak Load:

Select a gear coupling to connect a gear drive low-speed shaft to a reversing runout mill table. The electric motor rating is 50 hp at its base speed and the system peak torque at the coupling is estimated to be 150,000 lb-in. The coupling speed is 77 rpm at the motor base speed. Drive shaft diameter is 4.000" and keyway is 1.000" x 0.500". Runout table roll diameter is 5.250" and keyway is 1.250 x 0.625". Shaft separation is 0.500" maximum. Motor and drive shaft extensions are both 7.00" long.

1. **Type:** From **page 4**, to connect close-coupled shafts (0.50" gap), the double engagement Type G20 coupling is the selection.
2. **Required Minimum Coupling Rating:**  
Use the Reversing High Peak Torque formula in Step 1B.  
 $1.5 \times 150,000 = 225,000$  Selection Torque
3. **Size:** From **Table 1**, Size 1040G20 coupling with torque rating of 270,900 exceeds the selection torque of 225,000 lb-in.
4. **Check:** The maximum bore of 5.75", from **Table 13, page 38**, the allowable speed of 3600 and Dimension M of 5.70" on **page 13** meet the requirements.

# QUICK SELECTION METHOD

## 1. Select Coupling Type.

The Type G20 coupling is the proper selection for most industrial applications. For quick disconnect couplings, especially suited for pump applications, consider the Type G32 spacer coupling. If an application requires a special purpose coupling, refer application details to the local Regal Rexnord™ representative.

## 2. Determine Service Factor.

- A. For motor, turbine or engine-driven applications, refer to **Tables 4 and 5**.
- B. For brake, high peak load and Type GL slide coupling applications, refer to Formula Selection Method on **page 7**.

## 3. Determine Equivalent Horsepower.

Refer to **Table 2** below. Under the actual motor hp required and opposite the service factor determined in Step 2, read the equivalent hp.

## 4. Determine Coupling Size.

- A. Refer to **Table 3**. Trace horizontally from the required speed to a value equal to or larger than the equivalent horsepower determined in Step 3. Read the coupling size at the top of the column.
- B. Check shaft diameters against coupling maximum bores. If a larger bore is required, select a larger coupling.

- C. Check the required speed against the allowable speed of the coupling selected. If a higher speed is required, refer complete details to the local Regal Rexnord representative.
- D. Check dimensions ... Dimension M in particular.

### Example:

Select a gear coupling to connect a 450 hp, 1170 rpm electric motor to a gear drive high-speed shaft of a maneuvering winch. Maximum shaft separation is 0.250". Motor shaft diameter is 3.500" and the gear drive shaft is 3.000". Motor and gear drive shaft extensions are both 6.00" long.

### Selection:

1. To connect close-coupled shafts (0.250" gap) and to accommodate anticipated shaft misalignment, the double engagement Type G20 coupling shown on **page 13** is the selection.
2. From **Table 4**, the Service Factor is 1.5.
3. From **Table 2** below, the equivalent hp is 675.
4. From **Table 3**, the coupling size is 1025G for 1170 rpm and equivalent hp of 675. From the table on **page 13**, the maximum bore of 3.625", allowable speed of 5000 rpm and Dimension M of 3.60" are all satisfactory.

**TABLE 2 – Equivalent Horsepower = (Actual HP x Service Factor)**

Service Factor ①	Actual HP																									
	3/4	1	1-1/2	2	3	5	7-1/2	10	15	20	25	30	40	50	60	75	100	125	150	200	250	300	350	400	450	500
1.00	0.75	1.0	1.5	2.0	3.0	5.0	7.5	10	15	20	25	30	40	50	60	75	100	125	150	200	250	300	350	400	450	500
1.25	0.94	1.25	1.9	2.5	3.8	6.3	9.4	12.5	19	25	31	38	50	63	75	94	125	156	188	250	312	375	438	500	563	625
1.50	1.1	1.5	2.3	3.0	4.5	7.5	11.3	15	23	30	38	45	60	75	90	113	150	188	225	300	375	450	525	600	675	750
1.75	1.3	1.8	2.6	3.5	5.3	8.8	13.1	18	26	35	44	53	70	88	105	131	175	219	262	350	438	525	613	700	787	875
2.00	1.5	2.0	3.0	4.0	6.0	10.0	15.0	20	30	40	50	60	80	100	120	150	200	250	300	400	500	600	700	800	900	1000
2.50	1.9	2.5	3.8	5.0	7.5	12.5	18.8	25	38	50	63	75	100	125	150	187	250	312	375	500	625	750	875	1000	1125	1250
3.00	2.3	3.0	4.5	6.0	9.0	15.0	22.5	30	45	60	75	90	120	150	180	225	300	375	450	600	750	900	1050	1200	1350	1500
3.50	2.6	3.5	5.3	7.0	10.5	17.5	26.2	35	52	70	87	105	140	175	210	262	350	437	525	700	875	1050	1225	1400	1575	1750

① For Service Factors not listed, Equivalent HP = Actual HP x Service Factor.

# QUICK SELECTION METHOD (Cont.)

**TABLE 3 – Coupling Selection ... Based on Equivalent HP Ratings**

	1010G	1015G	1020G	1025G	1030G	1035G	1040G	1045G	1050G	1055G	1060G	1070G
Max Bore (G10/G20) (in)	1.875	2.375	2.875	3.625	4.125	4.875	5.750	6.750	7.375	8.250	9.125	10.875
Max Speed (G10/G20)	8000	6500	5600	5000	4400	3900	3600	3200	2900	2650	2450	2150
Torque (lb-in)	10,080	20,790	37,800	66,150	107,100	163,800	270,900	371,700	500,900	655,200	800,100	1,197,000
HP / 100 RPM	16	33	60	105	170	260	430	590	795	1040	1270	1900
RPM	HP Ratings											
4500	720	1480	2700	4720	7650	11700	19300	–	–	–	–	–
3600	576	1190	2160	3780	6120	9360	15500	–	–	–	–	–
3000	480	990	1800	3150	5100	7800	12900	17700	–	–	–	–
2500	400	825	1500	2620	4250	6500	10700	14700	19900	26000	–	–
2100	336	693	1260	2200	3570	5460	9000	12400	16700	21800	26700	39900
1800	288	594	1080	1890	3060	4680	7700	10600	14300	18700	22900	34200
1750	280	577	1050	1840	2970	4550	7522	10300	13900	18200	22200	33200
1450	232	478	870	1520	2460	3770	6230	8550	11500	15100	18400	27500
1170	187	386	702	1230	1990	3040	5030	6900	9300	12200	14900	22200
1000	160	330	600	1050	1700	2600	4300	5900	7950	10400	12700	19000
870	139	287	522	913	1480	2260	3740	5130	6910	9044	11000	16500
720	115	238	432	756	1220	1870	3090	4250	5720	7490	9140	13700
650	104	214	390	682	1100	1690	2790	3830.0	5170	6760	8250	12300
580	92.8	191	348	609	986	1507	2493	3420.6	4610	6030	7360	11000
520	83.2	172	312	546	884	1350	2240	3070	4130	5410	6600	9880
420	67.2	139	252	441	714	1090	1810	2480	3340	4370	5330	7980
350	56.0	115	210	367	595	910	1500	2060	2780	3640	4440	6650
280	44.8	92.4	168	294	476	728	1200	1650	2230	2910	3550	5320
230	36.8	75.9	138	241	391	598	989	1360	1830	2390	2920	4370
190	30.4	62.7	114	199	323	494	817	1120	1510	1980	2410	3610
155	24.8	51.1	93.0	163	263	403	666	914	1230	1610	1970	2940
125	20.0	41.2	75.0	131	212	325	537	737	993	1300	1590	2370
100	16.0	33.0	60.0	105	170	260	430	590	795	1040	1270	1900
84	13.4	27.7	50.4	88.2	143	218	361	495	668	873	1070	1600
68	10.9	22.4	40.8	71.4	116	177	292	401	540	707	863	1290
56	8.96	18.5	33.6	58.8	95.2	146	241	330	445	582	711	1060
45	7.20	14.8	27.0	47.2	76.5	117	193	265	358	468	571	855
37	5.92	12.2	22.2	38.8	62.9	96.2	159	218	294	385	470	703
30	4.80	9.90	18.0	31.5	51.0	78.0	129	177	238	312	381	570
25	4.00	8.25	15.0	26.2	42.5	65.0	107	147	199	260	317	475
20	3.20	6.60	12.0	21.0	34.0	52.0	86.0	118	159	208	254	380
16.5	2.64	5.44	9.90	17.3	28.0	42.9	70.9	97.3	131	172	209	313
13.5	2.16	4.45	8.10	14.2	22.9	35.1	58.0	79.6	107	140	171	256
11	1.76	3.63	6.60	11.5	18.7	28.6	47.3	64.9	87.4	114	140	209
9	1.44	2.97	5.40	9.45	15.3	23.4	38.7	53.1	71.5	93.6	114	171
7.5	1.20	2.47	4.50	7.87	12.7	19.5	32.2	44.2	59.6	78.0	95.2	142
5	0.800	1.65	3.00	5.25	8.50	13.0	21.5	29.5	39.7	52.0	63.5	95.0

# SERVICE FACTORS

TABLE 4

Application	Service Factor
<b>AERATOR</b>	2.0
<b>AGITATORS</b>	
Vertical and Horizontal Screw, Propeller, Paddle	1.0
Pure Liquids	1.0
Liquids & Solids	1.25
Liquids - variable density	1.25
<b>AGGREGATE PROCESSING, CEMENT, MINING KILNS; TUBE, ROD AND BALL MILLS</b>	
Direct or on L.S. shaft of Reducer, with final drive	
Machined Spur Gears	2.0
Single Helical or Herringbone Gears	1.75
Conveyors, Feeders, Screens, Elevators	See General Listing
Crushers, Ore or Stone	2.5
Dryer, Rotary	1.75
Grizzly	2.0
Hammermill or Hog	1.75
Tumbling Mill or Barrel	1.75
<b>BARGE HAUL PULLER</b>	1.5
<b>BRIQUETTE MACHINES</b>	2.0
<b>BLOWERS</b>	
Centrifugal	1.0
Centriaxial	1.25
Lobe	1.5
Vane	1.25
<b>BREWING AND DISTILLING</b>	
Bottle and Can Filling Machines	1.0
Brew Kettle	1.0
Cookers, Continuous Duty	1.25
Lauter Tub	1.5
Mash Tub	1.25
Scale Hopper, Frequent Peaks	1.75
<b>CAR DUMPERS</b>	2.5
<b>CAR PULLERS</b>	1.5
<b>CAR PULLERS - Intermittent Duty</b>	1.5
<b>CAR SHREDDER</b>	3.0
<b>CLARIFIER OR CLASSIFIER</b>	1.0
<b>COMPRESSORS</b>	
Centrifugal	1.0
Centriaxial	1.25
Rotary, Lobe or Vane	1.25
Lobe	1.5
Rotary, Screw	1.0
<b>Reciprocating</b>	
Multi-Cylinder	2.0
Direct Connected	Refer to factory
Without Flywheel	Refer to factory
⊙ <b>With Flywheel and Gear between Compressor and Prime Mover</b>	
1 cylinder, single acting	3.0
1 cylinder, double acting	3.0
2 cylinders, single acting	3.0
2 cylinders, double acting	3.0
3 cylinders, single acting	3.0
3 cylinders, double acting	2.0
4 or more cyl., single act.	1.75
4 or more cyl., double act.	1.75
<b>CONVEYORS-LIGHT DUTY UNIFORMLY FED (3)</b>	
Apron, Chain, Flight, Screw	1.25
Bucket	1.25
Assembly, Belt	1.0
Oven	1.5
Live Roll, Shaker and Reciprocating	3.0
<b>CONVEYORS-LIGHT DUTY NOT UNIFORMLY FED</b>	
Apron, Bucket, Chain, Flight, Oven	1.5
Assembly, Belt	1.25
Reciprocating, shaker	2.5
⊙⊙ <b>CRANES AND HOIST</b>	
Main Hoist	1.7 ⊙
Skip Hoist	1.75 ⊙
Slope	1.5
Bridge, Travel or Trolley	1.75
<b>CRANES AND HOIST (NOTES 1 and 2)</b>	
Main Hoists, Reversing	2.5
Skip Hoists, Trolley & Bridge Drives	2.0
Slope	2.0
<b>CLAY WORKING INDUSTRY</b>	
Brick Press, Briquette Machine, Clay Working Machine, Pug Mill	1.75
<b>DYNAMOMETER</b>	1.0
<b>CRUSHERS</b>	
Ore, Stone	3.0
<b>DREDGES</b>	
Cable Reels	1.75
Conveyors	1.5
Cutter head Jig Drives	2.5
Maneuvering Winches	1.75
Pumps	1.75
Pumps (Uniform Load)	1.5
Screen Drive, Stacker	1.75
Utility Winches	1.5
<b>ELEVATORS</b>	
Bucket, Centrifugal Discharge	1.25
Freight or Passenger	Not Approved
Gravity Discharge	1.25
<b>ELEVATORS (NOTE 2)</b>	
Bucket	1.75
Centrifugal & Gravity Discharge	1.5
Escalators	1.5
Freight	2.5
<b>ESCALATORS</b>	Not Approved
<b>EXCITER, GENERATOR</b>	1.0
<b>EXTRUDER, PLASTIC</b>	1.5

Application	Service Factor
<b>FANS</b>	
Centrifugal	1.0
Cooling Tower	2.0
Forced Draft — Across the line start	1.5
Forced Draft Motor driven thru fluid or electric slip clutch	1.0
Forced Draft	1.5
Gas Recirculating	1.5
Induced Draft with damper control or blade cleaner	1.25
Induced Draft without controls	2.0
<b>FEEDERS</b>	
Apron, Belt, Disc, Screw	1.25
Reciprocating	2.5
<b>FOOD INDUSTRY</b>	
Beet Slicer	1.75
Bottling, Can Filling Machine	1.0
Cereal Cooker	1.25
Dough Mixer, Meat Grinder	1.75
<b>GENERATORS</b>	
Even Load	1.0
Hoist or Railway Service	1.5
Welder Load	2.0
(Not Welding)	1.0
<b>HAMMERMILL</b>	2.0
<b>LAUNDRY WASHER OR TUMBLER</b>	2.0
<b>LAUNDRY WASHERS</b>	
Reversing	2.0
<b>LAUNDRY TUMBLERS</b>	2.0
<b>LINE SHAFTS</b>	
Any Processing Machinery	1.5
<b>LUMBER</b>	
Band Resaw	1.5
Circular Resaw, Cut-off	1.75
Edger, Head Rig, Hog	2.0
Gang Saw (Reciprocating)	Refer to factory
Log Haul	2.0
Planer	1.75
Rolls, Non-Reversing	1.25
Rolls, Reversing	2.0
Sawdust Conveyor	1.25
Slab Conveyor	1.75
Sorting Table	1.5
Trimmer	1.75
Barkers - Drum Type	2.0
Edger Feed	2.0
Live Rolls	2.0
Log Haul - Incline	2.0
Log Haul - Well type	2.0
Off Bearing Rolls	2.0
Planer Feed Chains	1.75
Planer Floor Chains	1.75
Planer Tilting Hoist	1.75
<b>MACHINE TOOLS</b>	
Auxiliary and Traverse Drive	1.0
Bending Roll, Notching Press, Punch Press, Planer, Plate Reversing	1.75
Main Drive	1.5
Bending Roll	2.0
Plate Planer	1.5
Punch Press - Gear Driven	2.0
Tapping Machines	2.5
<b>Other Machine Tools:</b>	
Main Drives	1.5
Auxiliary Drives	1.25
<b>MAN LIFTS</b>	Not Approved
<b>MARINE PROPULSION</b>	
Main Drives	2.25 - 2.5
<b>METAL FORMING MACHINES</b>	
Continuous Caster	1.75
Draw Bench Carriage and Main Drive	2.0
Extruder	2.0
Farming Machine and Forming Mills	2.0
Slitters	1.5
Wire Drawing or Flattening	2.0
Wire Winder	1.75
Coilers and Uncoilers	1.5
<b>Table Conveyors</b>	
Non-Reversing	2.25
Reversing	2.5
<b>MIXERS (see Agitators)</b>	
Concrete	1.75
Muller	1.5
⊙ <b>METAL ROLLING MILLS/ (NOTE 1)</b>	
Blooming Mills	*
Coilers (Up or Down) Cold Mills only	1.5
Coilers (Up or Down) Hot Mills only	2.0
Cold Mills	2.0
Feed Rolls, Reversing Mills	3.5
Reel Drums	2.0
Roughing Mill Delivery Table	3.0
Saws, hot & cold	2.5
Tables, transfer & runout	2.0
Traction Drive	3.0
<b>Coke Plants</b>	
Pusher Ram Drive	2.5
Door Opener	2.0
Pusher or Larry Car Traction Drive	3.0
Continuous Caster	1.75
Cold Mills — Strip Mills	Refer to factory
Temper Mills	Refer to factory
Cooling Beds	1.75
Drawbench	2.0
Feed Rolls - Blooming Mills	3.0
Furnace Pushers	2.5
Hot and Cold Saws	2.0

Application	Service Factor
<b>HOT MILLS</b>	3.0
Strip or Sheet Mills	Refer to factory
Reversing Blooming	Refer to factory
Slabbing Mills	Refer to factory
Edger Drives	Refer to factory
Ingot Cars	2.5
Manipulators	3.0
Merchant Mills	Refer to factory
Mill Tables	
Roughing Breakdown Mills	3.0
Hot Bed or Transfer, non-reversing	1.5
Runout, reversing	3.0
Runout, non-reversing, non-plugging	2.0
Reel Drives	1.75
Rod Mills	Refer to factory
Rod and bar Mills	1.5
Screwdown	3.0
Seamless Tube Mills	
Piercer	3.0
Thrust Block	3.0
Tube Conveyor Rolls	2.5
Reeler	3.0
Kick Out	2.5
Shear, Croppers	Refer to factory
Sidguards	3.0
Skelp Mills	Refer to factory
Slitters	3.0
Slitters, Steel Mill only	1.75
<b>Soaking Pit Cover Drives</b>	3.0
Lift	1.0
Travel	2.0
Straighteners	2.5
Unscramblers (Billet Bundle Busters)	2.5
Wire Drawing Machinery	1.75
<b>MILLS, ROTARY TYPE</b>	
Ball	2.25
Dryers & Coolers	2.0
Hammer	1.75
Kilns	2.0
Pebble & Rod	2.0
Pug	1.75
Tumbling Barrels	2.0
<b>OIL INDUSTRY</b>	
Chiller	1.25
Oilwell Pumping (not over 150% peak torque)	2.0
Paraffin Filter Press	1.75
Rotary Kiln	2.0
<b>PAPER MILLS</b>	
Barker Auxiliary, Hydraulic	2.0
Barker, Mechanical	2.0
Winders	1.5
<b>Barking Drum</b>	
Spur Gear Only	2.25
L.S. Shaft of reducer with final drive - Helical or Herringbone Gear	2.0
Machined Spur Gear	2.5
Cast Tooth Spur Gear	3.0
Beater & Pulper	1.75
Bleachers, Coaters	1.0
Calenders	2.0
Calender & Super Calender	1.75
Chipper	2.5
Coaters	1.0
Converting Machine	1.25
Converting Machine except Cutters, Platers	1.5
Couch	1.75
Cutters, Platers	2.0
Cutter, Felt Whipper	2.0
Cylinder	1.75
Disc Refiners	1.75
Dryer	1.75
Felt Whipper	1.25
Felt Whipper	2.0
Fourdrinner	1.75
Jordan	2.0
Log Haul	2.0
Line Shaft	1.5
Press	2.0
Pulp Grinder	1.75
Reel	1.5
Reel, Rewinder, Winder	1.5
Stock Chest, Washer, Thickener	1.5
<b>Stock Pumps, Centrifugal</b>	
Constant Speed	1.0
Frequent Speed Changes Under Load	1.25
Suction Roll	1.75
Vacuum Pumps	1.25
<b>PRESS, PRINTING</b>	1.5
<b>PUG MILL</b>	1.75
<b>PULLERS - Barge Haul</b>	2.0
<b>PULVERIZERS</b>	
Hammermill and Hog	1.75
Roller	1.5
<b>PUMPS</b>	
Boiler Feed	1.5
Centrifugal	1.0
Centrifugal — Constant Speed	1.0
Frequent Speed Changes under Load	1.25
Descaling, with accumulators	1.25
Gear, Rotary, or Vane	1.25
<b>Reciprocating, Plunger Piston</b>	
1 cyl., single or double act.	3.0
2 cyl., single acting	2.0
2 cyl., double acting	1.75
3 or more cylinders	1.5

Application	Service Factor
<b>Reciprocating Single Acting</b>	
1 or 2 Cylinders	2.25
3 or more Cylinders	1.75
Double Acting	2.0
Rotary, Gear, Lobe, Vane	1.5
Screw Pump, Progressing Cavity	1.25
Vacuum Pump	1.25
<b>RUBBER INDUSTRY</b>	
Mixer - Banbury	2.5
Calender	2.0
Rubber Mill (2 or more)	2.25
Sheeter	2.0
Cracker, Plasticator	2.5
Extruder	1.75
Intensive or Banbury Mixer	2.5
<b>Mixing Mill, Refiner or Sheeter</b>	
One or two in line	2.5
Three or four in line	2.0
Five or more in line	1.75
Tire Building Machine	2.5
Tire & Tube Press Opener (Peak Torque)	1.0
Tuber, Strainer, Pelletizer	2.0
<b>Warming Mill</b>	
One or two Mills in line	2.0
Three or more Mills in line	1.75
Washer	2.5
<b>SCREENS</b>	
Air Washing	1.0
Grizzly	2
Rotary Coal or Sand	1.5
Vibrating	2.5
Travelling Water Intake	1.25
Water	1.0
<b>SEWAGE DISPOSAL EQUIPMENT</b>	
Bar Screen, Chemical Feeders, Collectors, Dewatering Screen, Grit Collector	1.25
Scum Breakers	1.25
Slow or Rapid Mixers	1.25
Sludge Collectors	1.25
Thickeners	1.25
Vacuum Filters	1.25
<b>SKI TOWS &amp; LIFTS</b>	Not Approved
<b>STEERING GEAR</b>	1.0
<b>STOKER</b>	1.0
<b>SUGAR INDUSTRY</b>	
Cane Carrier & Leveler	1.75
Cane Knife & Crusher	2.0
Mill Stands, Turbine Driver with all Helical or Herringbone gears	1.5
Electric Drive or Steam Engine Drive with Helical, Herringbone, or Spur Gears with any Prime Mover	1.75
<b>TEXTILE INDUSTRY</b>	
Batcher	1.25
Calender, Card Machine	1.5
Cloth Finishing Machine	1.5
Feed Can, Loom	1.5
Dyeing Machinery	1.25
Knitting Machine	Refer to factory
Mangle, Napper, Soaper	1.25
Spinner, Tentor Frame, Winder	1.5
<b>TIRE SHREDDER</b>	1.5
<b>TUMBLING BARREL</b>	1.75
<b>WINCH, MANEUVERING</b>	
Dredge, Marine	1.5
<b>WINDLASS</b>	1.75
<b>WOODWORKING MACHINERY</b>	1.0
<b>WORK LIFT PLATFORMS</b>	Not Approved

- ① Add 0.25 to the required service factor for Type GL slide coupling applications where axial movement occurs more than 5 times per hour. When electric motors, generators, engines, compressors and other machines are fitted with sleeve or straight roller bearings, use limited axial end float couplings to protect the bearings. Order limited end float discs with the coupling.
- ② For balanced opposed design, refer to the Factory.
- ③ If people are occasionally transported, refer to the Factory for the selection of the proper size coupling.
- ④ For high peak load applications (such as metal rolling mills) refer to the Factory.

# SERVICE FACTORS

**TABLE 5 – Engine Drive Service Factors** ①







Service Factors (S. F.) for engine drives are those required for applications where good flywheel regulation prevents torque fluctuations greater than  $\pm 20\%$ . For drives where torque fluctuations are greater or where the operation is near a serious critical or torsional vibration, a mass elastic study is necessary.

No. of Cylinders	4 or 5 ①					6 or more ①				
	<b>Table 4 S.F.</b>	1.0	1.25	1.5	1.75	2.0	1.0	1.25	1.5	1.75
<b>Engine S.F.</b>	2.0	2.25	2.5	2.75	3.0	1.5	1.75	2.0	2.25	2.5

① To use **Table 5**, first determine application service factor from **Table 4**. Use that factor to determine Engine Service Factor from **Table 5**. When service factor from **Table 4** is greater than 2.5, refer complete application details to the Factory for engineering review.

**SERVICE FACTORS** are a guide, based on experience, of the ratio between coupling catalog rating and system characteristics. The system characteristics are best measured with a torque meter.

**TABLE 6 – Service Factors**

Torque Demands Driven Machine	Typical applications for electric motor or turbine driven equipment	Typical Service Factor
	Constant torque such as Centrifugal Pumps, Blowers and Compressors.	1.0
	Continuous duty with some torque variations including Plastic Extruders, Forced Draft Fans.	1.5
	Light shock loads from Metal Extruders, Cooling Towers, Cane Knife, Log Haul.	2.0
	Moderate shock loading as expected from a Car Dumper, Stone Crusher, Vibrating Screen.	2.5
	Heavy shock load with some negative torques from Roughing Mills, Reciprocating Pumps, Compressors, Reversing Runout Tables.	3.0
	Applications like Reciprocating Compressors with frequent torque reversals, which do not necessarily cause reverse rotations.	Refer to Factory

# HOW TO ORDER

The following information is necessary to quote or ship to your exact requirements. Prompt service is assured if this information is given on your inquiry or order.

1. Application: Driver & Driven
2. Power: Normal hp, Maximum hp or Torque (lb-in)
3. Speed (rpm)
4. Quantity
5. Coupling Size and Type, Horizontal, Vertical; e. g., Size 1010, Type G20
6. Shaft gap or distance between shaft ends (BE Dimension)
7. Bore Sizes will be furnished as per **Table 35** on **page 48** unless specified differently.
8. Shaft Dimensions as follows:

**For Straight Shafts:**

Driving Shaft	Driven Shaft
Diameter U _____	Diameter U _____
Length V _____	Length V _____
Keyway _____	Keyway _____

**NOTE:** Provide shaft tolerances if different than those shown in **Table 24**, on **page 43**. For other shaft/bore requirements, consult Regal Rexnord.

**For Taper Shafts:** Specify if keyway is to be parallel to the axis or to the bore.

Diameter U _____	Across Flats _____
Length V _____	Corners ZW _____
Length W _____	Taper per Foot _____
Length X _____	Keyway _____
Length Y _____	

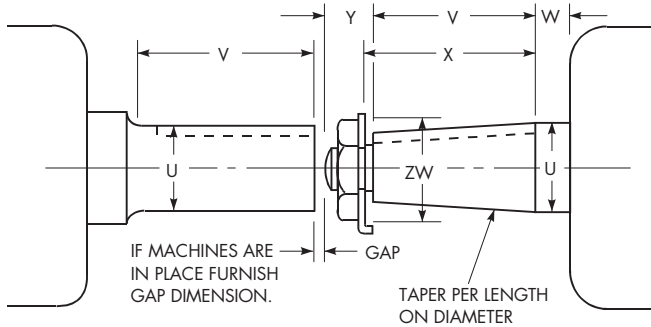

# PRODUCTS

## Safety Notes

Install and operate Regal Rexnord™ products in conformance with applicable local and national safety codes and per Regal Rexnord installation manuals which are available upon request. Suitable guards for rotating members may be purchased from Regal Rexnord as optional accessories. Consult your local Regal Rexnord representative for complete details.

**WARNING:** Lock out power and remove all external loads from the system before attempting to service any component in the system. Locking out the power and removing the load will reduce the possibility of unexpected motion or reaction in the system.

**Falk™ Long Term Grease (LTG)** — Benefits include: increased coupling life, significantly extended re-lubrication intervals, reduced maintenance costs, reduced downtime, superior lubrication, high load-carrying capabilities and it is usable up to 250° F (121° C).

For information on Falk LTG, request Form 840201B. Lifelign™ gear couplings are warranted for 3 years when lubricated with Falk LTG.

## Warranty

We're so confident in the performance and reliability of our latest generation of Falk gear drives that we're backing this comprehensive offering with the best standard warranty in the business. Our full, 3-year Heavy-Duty Warranty provides "shaft-to-shaft" protection on all Falk components – including bearings and seals. It's an industry first... and one more powerful reason why Regal Rexnord is your ultimate bottom-line drive and coupling value.\*

\* Warranty extends for 3 years from date of shipment.

## General Information

- Regal Rexnord standards apply unless otherwise specified.
- Dimensions are for reference only and are subject to change without notice unless certified.
- Unless otherwise specified, Falk Lifelign coupling hubs will be bored for an interference fit without a setscrew. Clearance fit hubs with a setscrew can be supplied if specified.

# TYPE G20 STANDARD FLANGED SLEEVE DOUBLE ENGAGEMENT

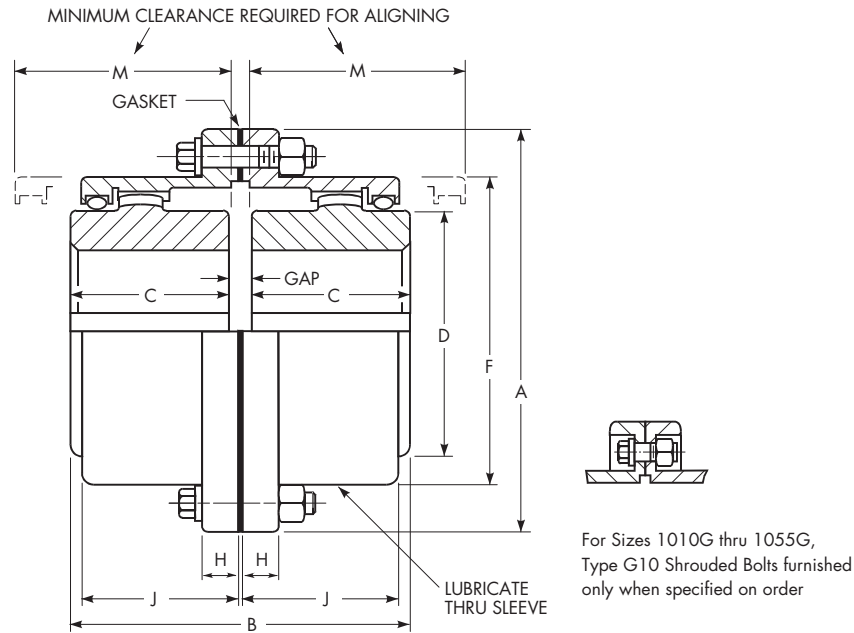

## Dimensions (in)

Size ①	Torque Rating (lb-in) ④	Allow Speed RPM ⑤	Max Bore ⑥	Min Bore ⑦	Cplg Wt With No Bore (lb)		Lube Wt (lb)	A	B	C	D	F	H	J	M	GAP
					G10	G20										
1010G	10,080	8,000	1.875	0.50	9	10	0.09	4.56	3.50	1.69	2.70	3.30	0.55	1.53	2.00	0.125
1015G	20,790	6,500	2.375	0.75	17	20	0.16	6.00	4.00	1.94	3.40	4.14	0.75	1.88	2.40	0.125
1020G	37,800	5,600	2.875	1.00	30	35	0.25	7.00	5.00	2.44	4.14	4.98	0.75	2.34	3.00	0.125
1025G	66,150	5,000	3.625	1.25	55	65	0.50	8.38	6.25	3.03	5.14	6.10	0.86	2.82	3.60	0.188
1030G	107,100	4,400	4.125	1.50	85	95	0.80	9.44	7.37	3.59	6.00	7.10	0.86	3.30	4.20	0.188
1035G	163,800	3,900	4.875	2.00	135	150	1.20	11.00	8.63	4.19	7.00	8.32	1.12	3.84	5.10	0.250
1040G	270,900	3,600	5.750	2.50	195	215	2.00	12.50	9.75	4.75	8.25	9.66	1.12	4.38	5.70	0.250
1045G	371,700	3,200	6.750	3.00	280	300	2.30	13.62	10.93	5.31	9.25	10.79	1.12	4.84	6.50	0.312
1050G	500,900	2,900	7.375	3.50	390	420	3.90	15.31	12.37	6.03	10.00	12.04	1.50	5.54	7.20	0.312
1055G	655,200	2,650	8.250	4.00	525	550	4.90	16.75	13.56	6.62	11.00	13.16	1.50	6.22	8.00	0.312
1060G	800,100	2,450	9.125	4.50	—	675	7.00	18.00	15.13	7.41	12.00	14.41	1.00	6.66	9.00	0.312
1070G	1,197,000	2,150	10.875	5.00	—	1070	9.60	20.75	17.75	8.69	14.00	16.73	1.12	7.70	10.50	0.375

TABLE 7 – Limited End Float & Standard Gap Disc Dimensions (in)

Size	B	End Float ②	Gap Disc ③		GAP
			Thickness	Dia	
1010G	3.58	0.094	0.156	2.95	0.203
1015G	4.08	0.094	0.156	3.70	0.203
1020G	5.11	0.094	0.188	4.50	0.234
1025G	6.39	0.094	0.281	5.55	0.328
1030G	7.54	0.094	0.312	6.50	0.359
1035G	8.79	0.188	0.312	7.55	0.406
1040G	9.91	0.188	0.312	8.95	0.406
1045G	11.15	0.188	0.438	9.95	0.531
1050G	12.59	0.188	0.438	10.95	0.531
1055G	13.80	0.188	0.469	12.00	0.563
1060G	15.45	0.188	0.532	13.12	0.625
1070G	18.10	0.188	0.625	15.10	0.718

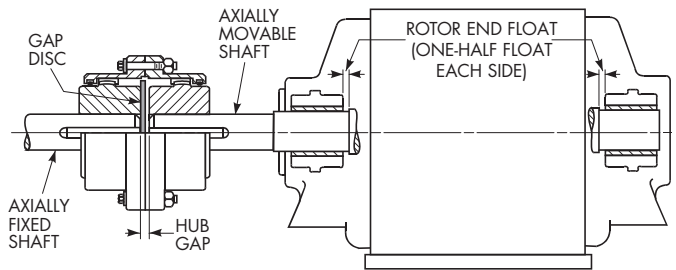

- ① See page 12 for General Information.
- ② If these values exceed one-half rotor end float or equivalent manufacturer's specification, refer to the Factory.
- ③ Gap disc material: Neoprene, 70 durometer.
- ④ Peak torque capacity is two times the published rating.
- ⑤ Consult Factory for higher speeds. Balancing may allow up to a 50% increase in speeds shown. Consult Factory or I & M manual for min. speeds with LTG NLGI1 greases.
- ⑥ Maximum bores are reduced for hubs furnished with an interference fit and a setscrew over the keyway. Maximum bores may also be reduced when puller bolt holes are required. Refer to Table 13 and Table 14 on page 38. Bore capacities can be increased beyond values shown if the coupling torque rating is reduced. Refer to the Factory. Recommended key sizes for the listed maximum bores are shown in Table 35, page 48, and Table 23, page 43.
- ⑦ Minimum bore is the smallest bore to which a Rough Stock Bore (RSB) hub can be bored. Depending upon coupling size, RSB hubs may have only a blind centering hole or a through hole that will permit remachining of the hubs to the minimum bores specified.

NOTE: Dimensions subject to change. Certified dimensions of ordered material furnished on request.

# TYPE G32 STANDARD FLANGED SLEEVE SPACER

## Without Limited End Float

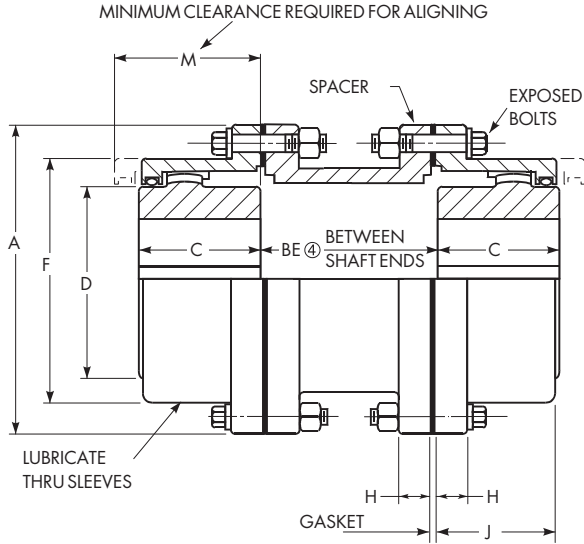

## Dimensions (in)

Size	End Float ①	SG	Addition to Stock BE Length ②
1015G	0.094	0.0235	0.088
1020G	0.094	0.0235	0.108
1025G	0.094	0.0235	0.145
1030G	0.094	0.0235	0.185
1035G	0.188	0.047	0.186
1040G thru 1070G	0.188	0.047	None

Size	Standard BE Spacers				
	3.500	4.375	4.500	5.000	7.000
1010G	X	X	—	X	—
1015G	X	—	—	X	—
1020G	—	X	—	X	X
1025G	—	—	—	X	X
1030G	—	—	—	X	X
1035G	—	—	X ⑨	—	—

## With Limited End Float

(Refer to drawing at left for balance of dimensions.)

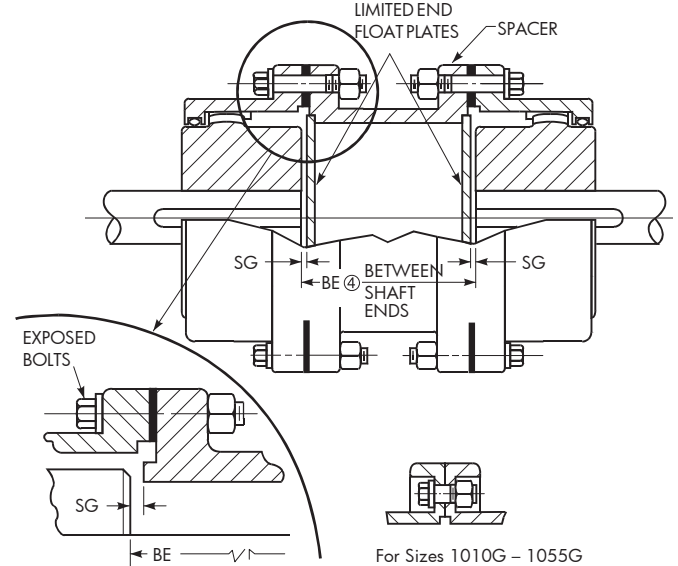

NON-STOCK SPACER DESIGN  
SIZES 1010 THRU 1070G32.

For Sizes 1010G – 1055G  
Type G31 Shrouded Bolts  
furnished only when  
specified on order.

## Dimensions (in)

Size ③	Torque Rating (lb-in) ⑤	Allow Speed RPM ⑥	Max Bore ⑦	Min Bore ⑧	Coupling Wt (lb)		Lube Wt (lb)		A	BE Min ④		C	D	F	H	J	M
					Cplg Wt with No Bore and Min BE	Extra Spacer Wt per in of Length	Min Wt Less Spacer	Plus per in of Spacer Length		G31	G32						
1010G	10,080	7,000	1.875	0.50	15	0.67	0.09	—	4.56	3.25	3.25	1.69	2.70	3.30	0.55	1.53	1.90
1015G	20,790	5,500	2.375	0.75	30	0.71	0.16	—	6.00	3.25	3.25	1.94	3.40	4.14	0.75	1.88	2.20
1020G	37,800	4,600	2.875	1.00	45	0.93	0.25	0.03	7.00	3.25	3.25	2.44	4.14	4.98	0.75	2.34	2.70
1025G	66,150	4,000	3.625	1.25	85	1.15	0.50	0.06	8.38	4.25	3.75	3.03	5.14	6.10	0.86	2.82	3.20
1030G	107,100	3,600	4.125	1.50	120	1.32	0.80	0.06	9.44	4.25	3.75	3.59	6.00	7.10	0.86	3.30	3.70
1035G	163,800	3,100	4.875	2.00	195	2.01	1.20	0.12	11.00	5.12	4.75	4.19	7.00	8.32	1.12	3.84	4.20
1040G	270,900	2,800	5.750	2.50	270	2.80	2.00	0.20	12.50	5.12	4.75	4.75	8.25	9.66	1.12	4.38	4.80
1045G	371,700	2,600	6.750	3.00	365	4.12	2.30	0.20	13.62	5.25	4.75	5.31	9.25	10.79	1.12	4.84	5.30
1050G	500,900	2,400	7.375	3.50	525	4.56	3.90	0.20	15.31	7.25	5.75	6.03	10.00	12.04	1.50	5.54	6.00
1055G	655,200	2,200	8.250	4.00	675	5.01	4.90	0.20	16.75	7.25	5.75	6.62	11.00	13.16	1.50	6.22	6.80
1060G	800,100	2,100	9.125	4.50	790	6.54	7.00	0.20	18.00	—	5.75	7.41	12.00	14.41	1.00	6.66	7.20
1070G	1,197,000	1,800	10.875	5.00	1240	7.91	9.60	0.20	20.75	—	5.75	8.69	14.00	16.73	1.12	7.70	8.20

- ① Refer to the Factory if these values exceed one-half the rotor end float or the equipment manufacturer's specifications.
- ② Couplings with stock spacers and limited end float must add applicable addition to the BE (Between Shaft Ends) dimension.
- ③ See **page 12** for General Information.
- ④ BE is the distance between shaft ends whether standard (stock) or special spacer lengths are used.
- ⑤ Peak torque capacity is two times the published rating.
- ⑥ Consult Factory for higher speeds. Balancing may allow up to a 50% increase in speeds shown.
- ⑦ Maximum bores are reduced for hubs furnished with an interference fit and a setscrew over the keyway. Maximum bores may also be reduced when puller bolt holes are required. Refer to **Table 13 and Table 14 on page 38**. Bore capacities can be increased beyond values shown if the coupling torque rating is reduced. Refer to the Factory. Recommended key sizes for the listed maximum bores are shown in **Table 35, page 48**, and **Table 23, page 43**.
- ⑧ Minimum bore is the smallest bore to which a Rough Stock Bore (RSB) hub can be bored. Depending upon coupling size, RSB hubs may have only a blind centering hole or a through hole that will permit remachining of the hubs to the minimum bores specified.
- ⑨ Bolt holes staggered for assembly clearance.

**NOTE:** Dimensions subject to change. Certified dimensions of ordered material furnished on request.

# TYPE G52 STANDARD FLANGED SLEEVE SINGLE ENGAGEMENT

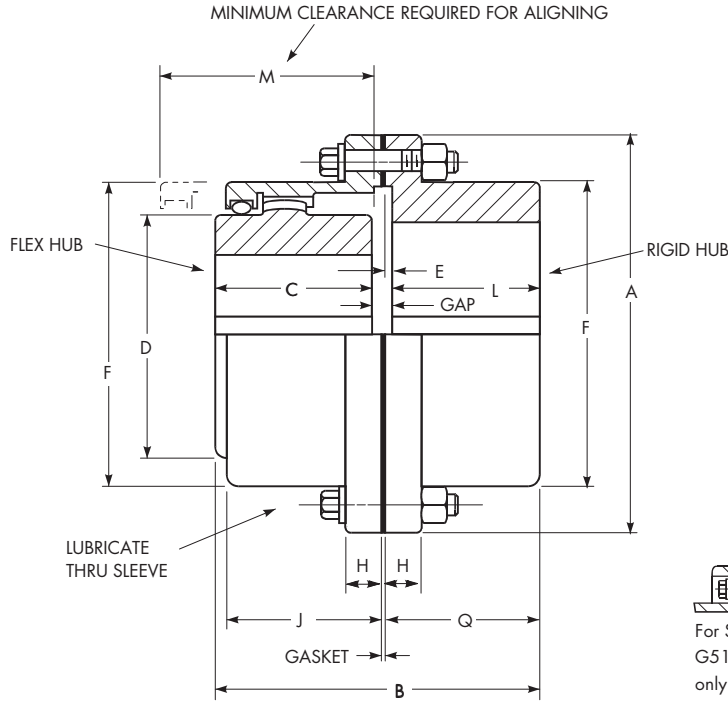

For Sizes 1010G thru 1055G, Type G51 Shrouded Bolts furnished only when specified on order.

## Dimensions (in)

Size ①	Torque Rating (lb-in) ②	Allow Speed RPM ③	Max Bore ④		Min Bore ⑤	Cplg Wt with No Bore (lb)		Lube Wt (lb)	A	B	C	D	E	F	H	J	L	M	Q	GAP
			Flex Hub	Rigid Hub		G51	G52													
1010G	10,080	8,000	1.875	2.375	0.50	9	10	0.05	4.56	3.41	1.69	2.70	0.10	3.30	0.55	1.53	1.56	2.00	1.66	0.156
1015G	20,790	6,500	2.375	2.938	0.75	18	20	0.09	6.00	3.92	1.94	3.40	0.10	4.14	0.75	1.88	1.82	2.40	1.92	0.156
1020G	37,800	5,600	2.875	3.625	1.00	30	35	0.15	7.00	4.90	2.44	4.14	0.10	4.98	0.75	2.34	2.30	3.00	2.40	0.156
1025G	66,150	5,000	3.625	4.375	1.25	55	60	0.26	8.38	6.12	3.03	5.14	0.10	6.10	0.86	2.82	2.90	3.60	3.00	0.188
1030G	107,100	4,400	4.125	5.125	1.50	85	95	0.40	9.44	7.24	3.59	6.00	0.10	7.10	0.86	3.30	3.46	4.20	3.56	0.188
1035G	163,800	3,900	4.875	5.875	2.00	135	150	0.60	11.00	8.43	4.19	7.00	0.10	8.32	1.12	3.84	4.02	5.10	4.12	0.218
1040G	270,900	3,600	5.750	7.250	2.50	200	220	1.03	12.50	9.56	4.75	8.25	0.16	9.66	1.12	4.38	4.54	5.70	4.70	0.281
1045G	371,700	3,200	6.750	8.125	3.00	285	300	1.25	13.62	10.75	5.31	9.25	0.16	10.79	1.12	4.84	5.14	6.50	5.30	0.312
1050G	500,900	2,900	7.375	9.000	3.50	400	430	2.00	15.31	12.17	6.03	10.00	0.20	12.04	1.50	5.54	5.80	7.20	6.00	0.344
1055G	655,200	2,650	8.250	10.000	4.00	555	580	2.50	16.75	13.76	6.62	11.00	0.20	13.16	1.50	6.22	6.80	8.00	7.00	0.344
1060G	800,100	2,450	9.125	11.000	4.50	—	715	3.75	18.00	15.16	7.41	12.00	0.26	14.41	1.00	6.66	7.34	9.00	7.60	0.406
1070G	1,197,000	2,150	10.875	13.000	5.00	—	1120	5.00	20.75	17.86	8.69	14.00	0.33	16.73	1.12	7.70	8.67	10.50	9.00	0.500

① See page 12 for General Information.

② Peak torque capacity is two times the published rating.

③ Consult Factory for higher speeds. Balancing may allow up to a 50% increase in speeds shown.

④ Maximum bores are reduced for hubs furnished with an interference fit and a setscrew over the keyway. Maximum bores may also be reduced when puller bolt holes are required. Refer to Table 13 and Table 14 on page 38. Bore capacities can be increased beyond values shown if the coupling torque rating is reduced. Refer to the Factory. Recommended key sizes for the listed maximum bores are shown in Table 35, page 48, and Table 23, page 43.

⑤ Minimum bore is the smallest bore to which a Rough Stock Bore (RSB) hub can be bored. Depending upon coupling size, RSB hubs may have only a blind centering hole or a through hole that will permit remachining of the hubs to the minimum bores specified.

NOTE: Dimensions subject to change. Certified dimensions of ordered material furnished on request.

# TYPE G52 STANDARD FLANGED SLEEVE SINGLE ENGAGEMENT (Cont.)

## Floating Shaft/Dimensions (in)

A standard floating shaft assembly consists of two standard single engagement couplings, two gap discs and a connecting shaft.

A floating shaft can eliminate the need for additional bearing supports along spanning shafts, because shaft is supported at ends by connected equipment through the single engagement couplings.

### Flex Hubs on Floating Shaft (RFFR)

Assembly of the flex hubs on the floating shaft allows for easier replacement in case of wear and allows the rigid hubs with their increased bore capacity to be used on the connected equipment shafts. This frequently means a smaller coupling size can be used.

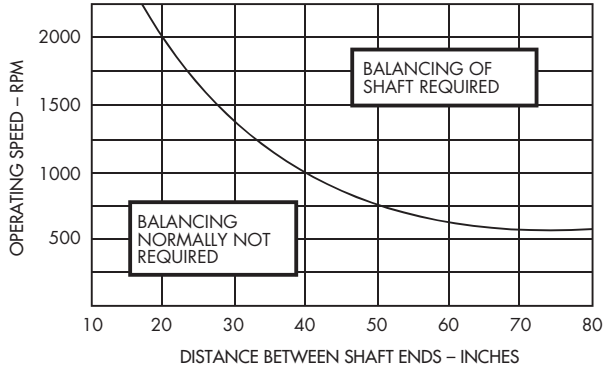

### Rigid Hubs on Floating Shaft (FRRF)

When the rigid hubs are on the floating shaft, shorter shaft spans can be accommodated, since no cover drawback is required. Since the flex hubs are outboard, the points of articulation are further apart, providing greater offset misalignment capacity.

### Solid Floating Shaft Selection

Single Engagement Type G52/GV52 couplings are used with floating shafts in either horizontal or vertical applications. For vertical applications, select a Type GV coupling for the lower coupling assembly. Select floating shafts as follows:

1. Use the Standard or Formula Selection Methods, **pages 6 and 7** to select the couplings. Record the System Torque from standard selection method or Selection Torque from formula selection method.
2. From the table below, select a shaft diameter that has an assembly torque rating equal to or greater than the system or selection torque determined in coupling selection.
3. Check maximum "BE" for the shaft diameter selected and running speed for the shaft length required from the table below. Refer to the graph at left to determine if the shaft requires balancing.
4. If the application shaft length exceeds the maximum "BE" listed, select the next larger shaft diameter or the next larger size coupling. Consult the Factory for higher speeds or longer shaft lengths than listed below.

## Floating Shaft

Size ①	Assembly Torque Rating (lb-in) ②	SB Shaft End Diameter	SD Shaft Diameter	Weight (lb/in)	WR <sup>2</sup> (lb-in <sup>2</sup> /in)	Maximum BE for Various RPMs ③						
						1750	1430	1170	870	720	580	540 & Less
1010G	4,370	1.500	1.562	0.54	0.17	54	60	66	77	85	94	97
	10,080	1.875	2.000	0.89	0.45	61	68	75	87	96	107	110
1015G	10,350	2.000	2.125	1.00	0.57	63	70	77	90	99	110	113
	20,790	2.375	2.500	1.39	1.09	69	76	84	97	107	119	123
1020G	20,200	2.500	2.625	1.53	1.32	70	78	86	100	110	122	126
	37,800	2.875	3.000	2.00	2.25	75	83	92	107	117	131	135
1025G	39,500	3.125	3.250	2.35	3.10	78	87	96	111	122	136	140
	66,150	3.625	3.750	3.13	5.50	84	93	103	119	131	146	151
1030G	75,300	3.875	4.000	3.56	7.12	87	96	106	123	136	151	156
	107,100	4.125	4.250	4.02	9.07	89	99	110	127	140	156	160
1035G	118,000	4.500	4.750	5.02	14.16	95	105	116	134	148	165	169
	163,800	4.875	5.000	5.56	17.38	97	107	119	138	152	169	174
1040G	215,300	5.500	5.750	7.36	30.40	104	115	128	148	163	181	187
	270,900	5.750	6.000	8.01	36.05	106	118	130	151	166	185	191
1045G	279,500	6.000	6.500	9.40	49.65	111	123	136	157	173	193	198
	371,700	6.750	8.000	14.24	113.92	123	136	150	175	192	214	220
1050G	335,300	6.375	6.500	9.40	49.65	111	123	136	157	173	193	198
	500,900	7.375	8.000	14.24	113.92	123	136	150	175	192	214	220
1055G	335,300	6.375	6.500	9.40	49.65	111	123	136	157	173	193	198
	655,200	7.875	8.000	14.24	113.92	123	136	150	175	192	214	220
1060G	632,000	7.875	8.000	14.24	113.92	123	136	150	175	192	214	220
	800,100	8.500	8.560	16.30	149.33	127	141	156	181	199	221	228
1070G	632,000	7.875	8.000	14.24	113.92	123	136	150	175	192	214	220
	1,197,000	9.500	9.560	20.34	232.31	134	149	165	191	210	234	241

① See page 12 for General Information.

② Assembly torque rating is limited by coupling size, shaft end diameter or both.

③ Interpolate for intermediate speeds. Maximum BE is based on 70% of critical speed. Refer to the Factory for higher running speeds.

**NOTE:** Dimensions subject to change. Certified dimensions of ordered material furnished on request.

# TYPE G52 STANDARD FLANGED SLEEVE SINGLE ENGAGEMENT (Cont.)

## Floating Shaft

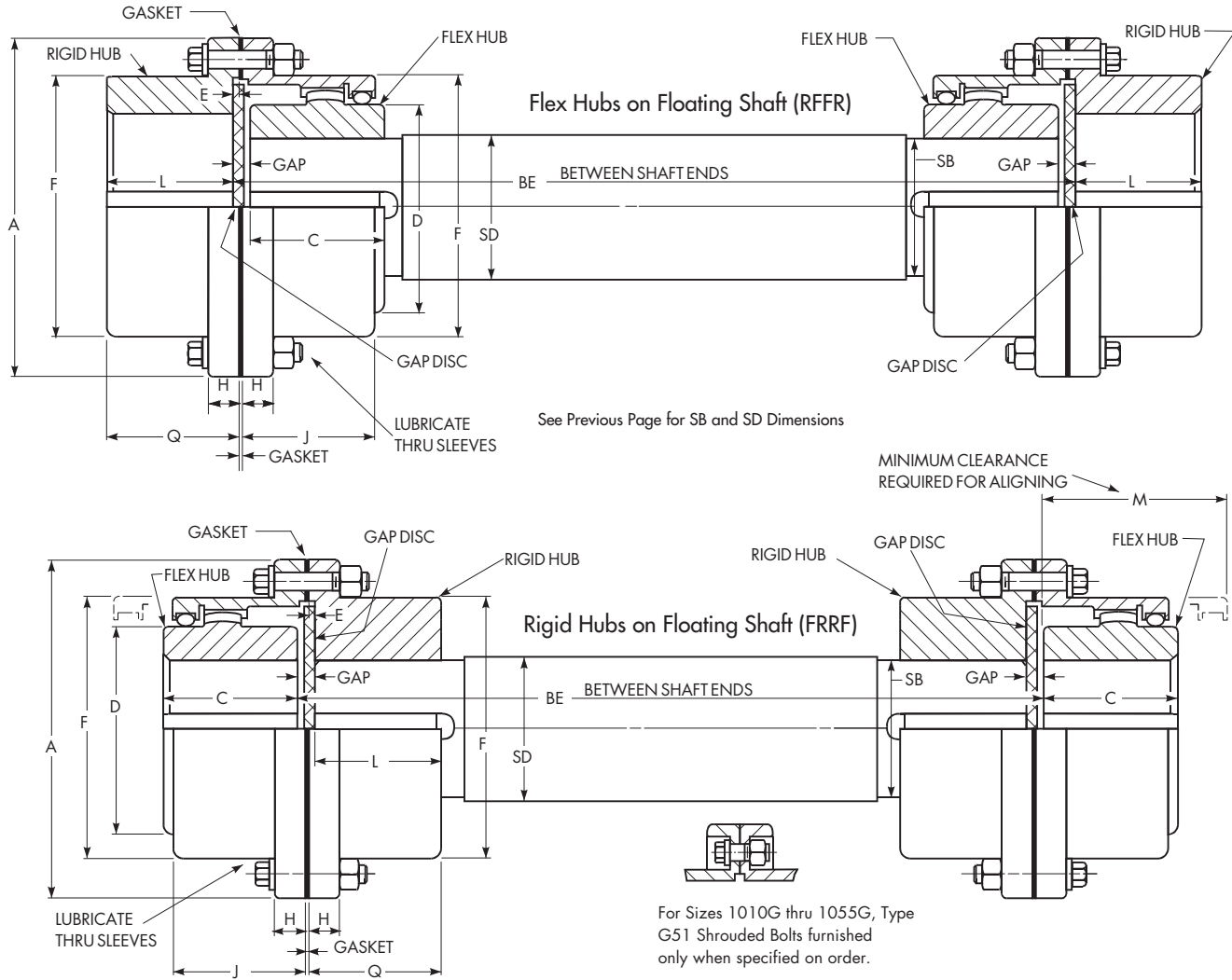

## Dimensions (in)

Size ①	Max Bore ②		Min Bore ③	Wt—One Cplg No Bore (lb)		Lube Wt per Cplg (lb)	A	BE Min		C	D	E	F	H	J	L	M	Q	GAP
	Flex Hub	Rigid Hub		G51	G52			RFFR	FRFF										
1010G	1.875	2.375	0.50	9	10	0.05	4.56	5.25	3.62	1.69	2.70	0.10	3.30	0.55	1.53	1.56	1.90	1.66	0.156
1015G	2.375	2.938	0.75	18	20	0.09	6.00	6.25	4.12	1.94	3.40	0.10	4.14	0.75	1.88	1.82	2.20	1.92	0.156
1020G	2.875	3.625	1.00	30	35	0.15	7.00	7.75	5.06	2.44	4.14	0.10	4.98	0.75	2.34	2.30	2.70	2.40	0.156
1025G	3.625	4.375	1.25	55	60	0.26	8.38	9.50	6.38	3.03	5.14	0.10	6.10	0.86	2.82	2.90	3.20	3.00	0.188
1030G	4.125	5.125	1.50	85	95	0.40	9.44	11.00	7.44	3.59	6.00	0.10	7.10	0.86	3.30	3.46	3.70	3.56	0.188
1035G	4.875	5.875	2.00	135	150	0.60	11.00	12.75	8.62	4.19	7.00	0.10	8.32	1.12	3.84	4.02	4.20	4.12	0.218
1040G	5.750	7.250	2.50	200	220	1.03	12.50	16.50	9.75	4.75	8.25	0.16	9.66	1.12	4.38	4.54	4.80	4.70	0.281
1045G	6.750	8.125	3.00	285	300	1.25	13.62	20.00	11.06	5.31	9.25	0.16	10.79	1.12	4.84	5.14	5.30	5.30	0.312
1050G	7.375	9.000	3.50	400	430	2.00	15.31	21.00	12.44	6.03	10.00	0.20	12.04	1.50	5.54	5.80	6.00	6.00	0.344
1055G	8.250	10.000	4.00	555	580	2.50	16.75	22.50	14.44	6.62	11.00	0.20	13.16	1.50	6.22	6.80	6.80	7.00	0.344
1060G	9.125	11.000	4.50	—	715	3.75	18.00	23.50	15.62	7.41	12.00	0.26	14.41	1.00	6.66	7.34	7.20	7.60	0.406
1070G	10.875	13.000	5.00	—	1120	5.00	20.75	26.50	18.50	8.69	14.00	0.33	16.73	1.12	7.70	8.67	8.20	9.00	0.500

① See page 12 for General Information.

② Maximum bores are reduced for hubs furnished with an interference fit and a setscrew over the keyway. Maximum bores may also be reduced when puller bolt holes are required. Refer to Table 13 and Table 14 on page 38. Bore capacities can be increased beyond values shown if the coupling torque rating is reduced. Refer to the Factory. Recommended key sizes for the listed maximum bores are shown in Table 35, page 48, and Table 23, page 43.

③ Minimum bore is the smallest bore to which a Rough Stock Bore (RSB) hub can be bored. Depending upon coupling size, RSB hubs may have only a blind centering hole or a through hole that will permit remachining of the hubs to the minimum bores specified.

NOTE: Dimensions subject to change. Certified dimensions of ordered material furnished on request.

# TYPE GV20 STANDARD FLANGED SLEEVE VERTICAL DOUBLE ENGAGEMENT

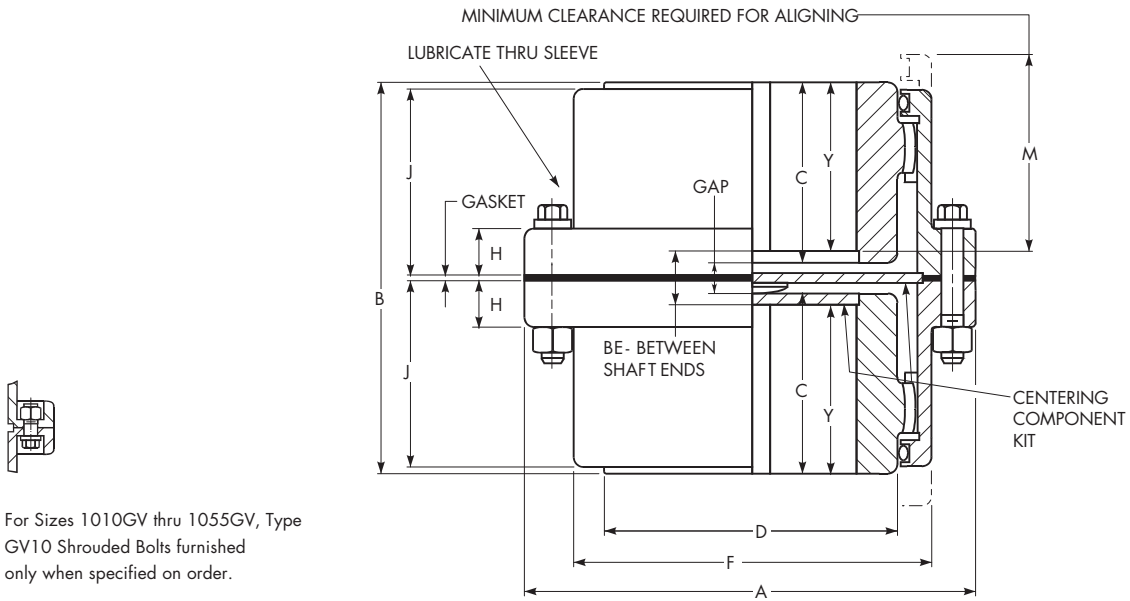

## Dimensions (in)

Size ①	Torque Rating (lb-in) ②	Allow Speed RPM ③	Max Bore ④	Min Bore ⑤	Cplg Wt with No Bore (lb)		Lube Wt (lb)	A	B	C	D	F	H	J	M	Y	BE	GAP
					GV10	GV20												
1010GV	10,080	8,000	1.875	0.50	8	9	0.18	4.56	3.50	1.53	2.70	3.30	0.55	1.53	1.80	1.28	0.94	0.438
1015GV	20,790	6,500	2.375	0.75	17	19	0.30	6.00	3.98	1.77	3.40	4.14	0.75	1.88	2.20	1.52	0.94	0.438
1020GV	37,800	5,600	2.875	1.00	30	32	0.50	7.00	4.98	2.27	4.14	4.98	0.75	2.34	2.80	2.02	0.94	0.438
1025GV	66,150	5,000	3.625	1.25	52	58	0.90	8.38	6.20	2.82	5.14	6.10	0.86	2.82	3.40	2.57	1.06	0.562
1030GV	107,100	4,400	4.125	1.50	80	90	1.40	9.44	7.34	3.39	6.00	7.10	0.86	3.30	4.00	3.14	1.06	0.562
1035GV	163,800	3,900	4.875	2.00	130	145	2.20	11.00	8.59	3.95	7.00	8.32	1.12	3.84	4.90	3.70	1.19	0.688
1040GV	270,900	3,600	5.750	2.50	195	215	3.20	12.50	9.72	4.42	8.25	9.66	1.12	4.38	5.50	4.17	1.38	0.875
1045GV	371,700	3,200	6.750	3.00	270	290	4.40	13.62	10.90	4.95	9.25	10.79	1.12	4.84	6.20	4.58	1.74	1.000
1050GV	500,900	2,900	7.375	3.50	380	410	6.30	15.31	12.34	5.67	10.00	12.04	1.50	5.54	6.90	5.30	1.74	1.000
1055GV	655,200	2,650	8.250	4.00	510	535	8.00	16.75	13.52	6.26	11.00	13.16	1.50	6.22	7.70	5.89	1.74	1.000
1060GV	800,100	2,450	9.125	4.50	—	665	10.60	18.00	15.12	7.00	12.00	14.41	1.00	6.66	8.70	6.62	1.88	1.125
1070GV	1,197,000	2,150	10.875	5.00	—	1050	15.60	20.75	17.74	8.18	14.00	16.73	1.12	7.70	10.00	7.67	2.40	1.375

① See page 12 for General Information.

② Peak torque capacity is two times the published rating.

③ Consult Factory for higher speeds. Balancing may allow up to a 50% increase in speeds shown.

④ Maximum bores are reduced for hubs furnished with an interference fit and a setscrew over the keyway. Maximum bores may also be reduced when puller bolt holes are required. Refer to Table 13 and Table 14 on page 38. Bore capacities can be increased beyond values shown if the coupling torque rating is reduced. Refer to the Factory. Recommended key sizes for the listed maximum bores are shown in Table 35, page 48, and Table 23, page 43.

⑤ Minimum bore is the smallest bore to which a Rough Stock Bore (RSB) hub can be bored. Depending upon coupling size, RSB hubs may have only a blind centering hole or a through hole that will permit remachining of the hubs to the minimum bores specified.

# TYPE GV52 STANDARD FLANGED SLEEVE VERTICAL SINGLE ENGAGEMENT

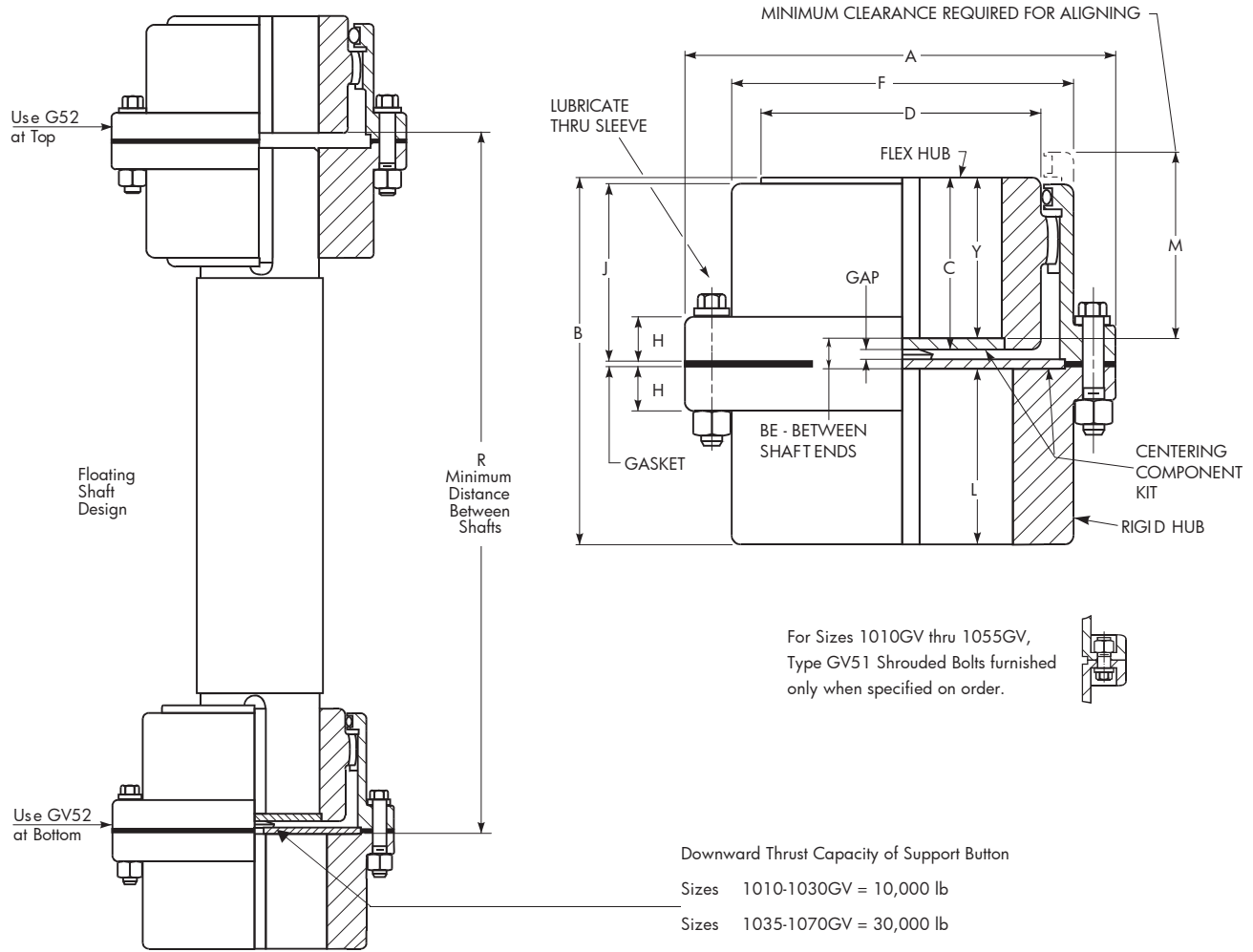

## Dimensions (in)

Size ①	Torque Rating (lb-in) ②④	Allow Speed RPM ③	Max Bore ⑤		Min Bore ⑥	Cplg Wt with No Bore (lb)		Lube Wt (lb)	A	B	C	D	F	H	J	L	M	R	Y	BE	GAP
			Flex Hub	Rigid Hub		GV51	GV52														
1010GV	10,080	7,000	1.875	2.375	0.50	9	10	0.08	4.56	3.42	1.53	2.70	3.30	0.55	1.53	1.56	1.80	5.18	1.28	0.580	0.140
1015GV	20,790	5,500	2.375	2.938	0.75	18	20	0.12	6.00	3.92	1.77	3.40	4.14	0.75	1.88	1.82	2.20	6.00	1.52	0.580	0.140
1020GV	37,800	4,600	2.875	3.625	1.00	32	35	0.20	7.00	4.90	2.27	4.14	4.98	0.75	2.34	2.30	2.80	7.20	2.02	0.580	0.140
1025GV	66,150	4,000	3.625	4.375	1.25	55	60	0.40	8.38	6.11	2.82	5.14	6.10	0.86	2.82	2.90	3.40	8.57	2.57	0.640	0.200
1030GV	107,100	3,600	4.125	5.125	1.50	85	95	0.60	9.44	7.24	3.39	6.00	7.10	0.86	3.30	3.46	4.00	9.75	3.14	0.640	0.200
1035GV	163,800	3,100	4.875	5.875	2.00	135	150	1.00	11.00	8.43	3.95	7.00	8.32	1.12	3.84	4.02	4.90	11.73	3.70	0.710	0.260
1040GV	270,900	2,800	5.750	7.250	2.50	205	225	1.50	12.50	9.58	4.42	8.25	9.66	1.12	4.38	4.54	5.50	13.40	4.17	0.865	0.300
1045GV	371,700	2,600	6.750	8.125	3.00	285	305	2.00	13.62	10.77	4.95	9.25	10.79	1.12	4.84	5.14	6.20	15.28	4.58	1.050	0.360
1050GV	500,900	2,400	7.375	9.000	3.50	405	435	3.00	15.31	12.19	5.67	10.00	12.04	1.50	5.54	5.80	6.90	16.68	5.30	1.090	0.315
1055GV	655,200	2,200	8.250	10.000	4.00	560	585	3.70	16.75	13.78	6.26	11.00	13.16	1.50	6.22	6.80	7.70	18.28	5.89	1.090	0.315
1060GV	800,100	2,100	9.125	11.000	4.50	—	860	5.00	18.00	15.18	7.00	12.00	14.41	1.00	6.66	7.34	8.70	20.56	6.62	1.215	0.315
1070GV	1,197,000	1,800	10.875	13.000	5.00	—	1140	7.20	20.75	17.88	8.18	14.00	16.73	1.12	7.70	8.67	10.00	24.22	7.67	1.540	0.380

- ① See page 12 for General Information.
- ② Torque Rating is for coupling only, refer to page 16 for floating shaft selection and ratings.
- ③ Allowable speed listed is for GV52 coupling only, refer to page 16 for floating shaft selection and running speed.
- ④ Peak torque capacity is two times the published rating.
- ⑤ Maximum bores are reduced for hubs furnished with an interference fit and a setscrew over the keyway. Maximum bores may also be reduced when puller bolt holes are required. Refer to Table 13 and Table 14 on page 38. Bore capacities can be increased beyond values shown if the coupling torque rating is reduced. Refer to the Factory. Recommended key sizes for the listed maximum bores are shown in Table 35, page 48, and Table 23, page 43.
- ⑥ Minimum bore is the smallest bore to which a Rough Stock Bore (RSB) hub can be bored. Depending upon coupling size, RSB hubs may have only a blind centering hole or a through hole that will permit remachining of the hubs to the minimum bores specified.

**NOTE:** Dimensions subject to change. Certified dimensions of ordered material furnished on request.

# TYPES G62, G63, G66 & G67 STANDARD FLANGED SLEEVE BRAKEWHEEL/DISC BRAKE

## Straight Bores — Wheel Sizes 7" Diameter & Larger

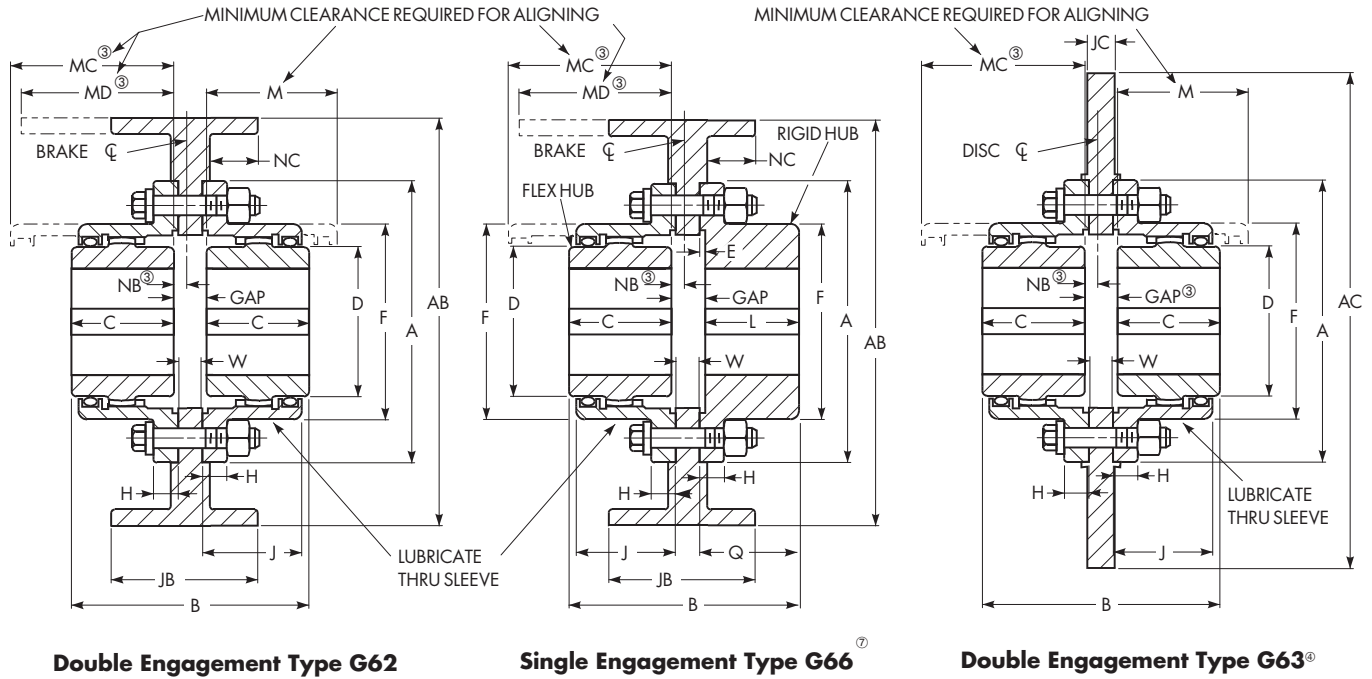

**Double Engagement Type G62**

**Single Engagement Type G66**

**Double Engagement Type G63**

### Dimensions (in)

Brake-Wheel Size ②	Cplg Size ①	Brake Rating of Coupling (ft-lb)	Max Straight Bore ⑤		Min Bore ⑥	Coupling Wt No Bore Less Wheel (lb)		Lube Wt (lb)		A	B		C	D	E	F	H	J	L	M	Q	W	GAP	
			Flex Hub	Rigid Hub		G62 G63	G66	G62 G63	G66		G62 G63	G66 with Std Length Hubs											G62 G63	G66
7	1010G	185	1.875	2.375	0.50	10	10	0.10	0.06	4.56	3.88	3.79	1.69	2.70	0.10	3.30	0.55	1.53	1.56	2.00	1.66	0.38	0.500	0.536
8	1015G	420	2.375	2.938	0.75	20	20	0.20	0.12	6.00	4.50	4.42	1.94	3.40	0.10	4.14	0.75	1.88	1.82	2.40	1.92	0.50	0.625	0.656
9.62	1020G	775	2.875	3.625	1.00	35	35	0.30	0.20	7.00	5.50	5.40	2.44	4.14	0.10	4.98	0.75	2.34	2.30	3.00	2.40	0.50	0.625	0.656
11.38	1025G	1400	3.625	4.375	1.25	65	60	0.60	0.35	8.38	6.81	6.68	3.03	5.14	0.10	6.10	0.86	2.82	2.90	3.60	3.00	0.56	0.750	0.748
12.62	1030G	2300	4.125	5.125	1.50	95	95	0.90	0.50	9.44	7.93	7.80	3.59	6.00	0.10	7.10	0.86	3.30	3.46	4.20	3.56	0.56	0.750	0.748
14.62	1035G	3550	4.875	5.875	2.00	150	150	1.25	0.75	11.00	9.38	9.18	4.19	7.00	0.10	8.32	1.12	3.84	4.02	5.10	4.12	0.75	1.000	0.968
16.88	1040G	5400	5.750	7.250	2.50	215	220	2.00	1.20	12.50	10.50	10.31	4.75	8.25	0.16	9.66	1.12	4.38	4.54	5.70	4.70	0.75	1.000	1.031
18	1045G	7400	6.750	8.125	3.00	300	300	2.50	1.40	13.62	11.68	11.50	5.31	9.25	0.16	10.79	1.12	4.84	5.14	6.50	5.30	0.75	1.062	1.062
19.38	1050G	10000	7.375	9.000	3.50	420	430	4.12	2.50	15.31	13.37	13.17	6.03	10.00	0.20	12.04	1.50	5.54	5.80	7.20	6.00	1.00	1.312	1.344
20.88	1055G	13125	8.250	10.000	4.00	550	580	5.12	3.00	16.75	14.56	14.76	6.62	11.00	0.20	13.16	1.50	6.22	6.80	8.00	7.00	1.00	1.312	1.344
23	1060G	17000	9.125	11.000	4.50	675	715	7.50	4.25	18.00	16.12	16.16	7.41	12.00	0.26	14.41	1.00	6.66	7.34	9.00	7.60	1.00	1.312	1.406
26	1070G	24700	10.875	13.000	5.00	1070	1120	9.80	5.75	20.75	18.75	18.86	8.69	14.00	0.33	16.73	1.12	7.70	8.67	10.50	9.00	1.00	1.375	1.500

- ① See page 12 for General Information.
- ② Maximum rim velocity is 6000 feet per minute. Brake wheel must be balanced if peripheral speed exceeds 6000 feet per minute.
- ③ Dimensions and allowable speed vary with application; consult the Factory.
- ④ Dimensions AC and JC depend upon customer caliper specifications.
- ⑤ Maximum bores are reduced for hubs furnished with an interference fit and a setscrew over the keyway. Maximum bores may also be reduced when puller bolt holes are required. Refer to Table 13 and Table 14 on page 38. Bore capacities can be increased beyond values shown if the coupling torque rating is reduced. Refer to the Factory. Recommended key sizes for the listed maximum bores are shown in Table 35, page 48, and Table 23, page 43.
- ⑥ Minimum bore is the smallest bore to which a Rough Stock Bore (RSB) hub can be bored. Depending upon coupling size, RSB hubs may have only a blind centering hole or a through hole that will permit remachining of the hubs to the minimum bores specified.
- ⑦ Also available in G67 disc configuration.

**NOTE:** Dimensions subject to change. Certified dimensions of ordered material furnished on request.

# TYPE GL20 STANDARD FLANGED SLEEVE SLIDE DOUBLE ENGAGEMENT

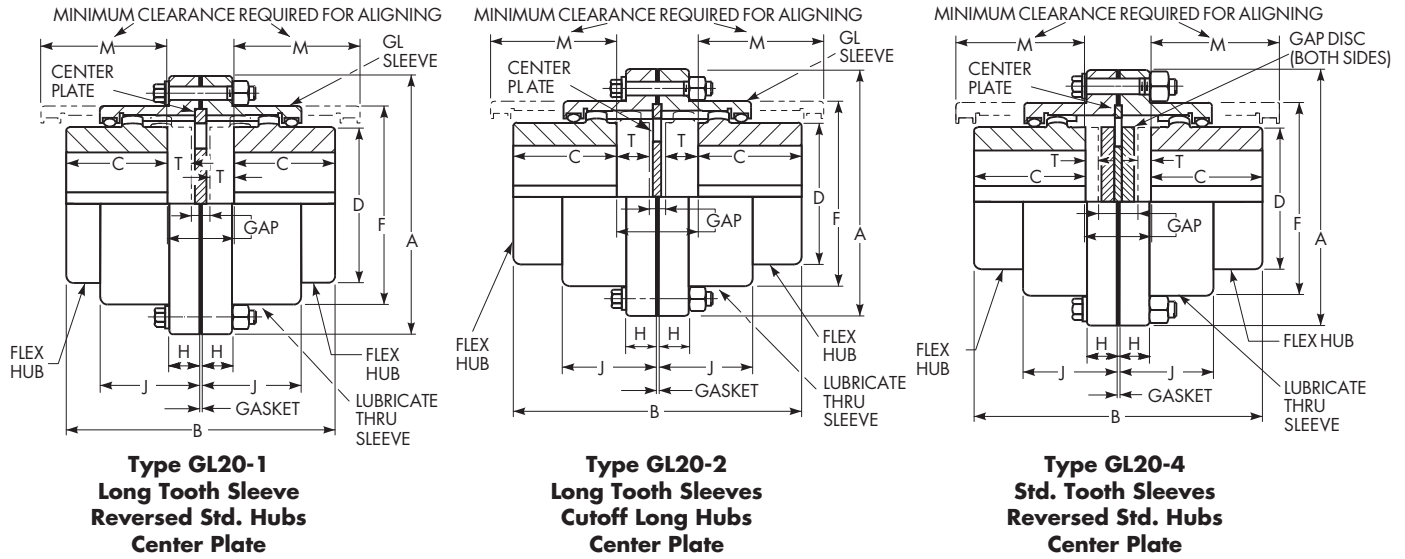

## Choosing an Assembly

Select the assembly that provides a Total "T" dimension from the table below equal to the application requirements.

- GL20-1 Moderate slide capacity, moderate price.
- GL20-2 Greatest slide capacity, highest price.
- GL20-4 Least slide capacity, lowest price.

## Dimensions (in)

Size ①	Torque Rating (lb-in) ③	Allow Speed RPM ④	Max Bore ⑤	Min Bore ⑥	Cplg Wt with No Bore (lb)	Lube Wt (lb)	A	C	D	F	H	J
1010GL	10,080	5,300	1.875	0.50	10	0.05	4.56	1.69	2.70	3.30	0.55	1.53
1015GL	20,790	4,300	2.375	0.75	20	0.08	6.00	1.94	3.40	4.14	0.75	1.88
1020GL	37,800	3,700	2.875	1.00	35	0.14	7.00	2.44	4.14	4.98	0.75	2.34
1025GL	66,150	3,300	3.625	1.25	65	0.25	8.38	3.03	5.14	6.10	0.86	2.82
1030GL	107,100	2,900	4.125	1.50	90	0.40	9.44	3.59	6.00	7.10	0.86	3.30
1035GL	163,800	2,600	4.875	2.00	150	0.60	11.00	4.19	7.00	8.32	1.12	3.84
1040GL	270,900	2,400	5.750	2.50	220	1.00	12.50	4.75	8.25	9.66	1.12	4.38
1045GL	371,700	2,100	6.750	3.00	300	1.12	13.62	5.31	9.25	10.79	1.12	4.84
1050GL	500,900	1,900	7.375	3.50	425	2.00	15.31	6.03	10.00	12.04	1.50	5.54
1055GL	655,200	1,800	8.250	4.00	560	2.50	16.75	6.62	11.00	13.16	1.50	6.22
1060GL	800,100	1,600	9.125	4.50	700	3.50	18.00	7.41	12.00	14.41	1.00	6.66
1070GL	1,197,000	1,400	10.875	5.00	1100	4.80	20.75	8.69	14.00	16.73	1.12	7.70

Size ①	Type GL20-1						Type GL20-2						Type GL20-4 ②					
	B Max	M	T (Max)		GAP		B Max	M	T (Max)		GAP		B Max	M	T (Max)		GAP	
			Each	Total	Min	Max			Each	Total	Min	Max			Each	Total	Min	Max
1010GL	3.79	2.12	0.05	0.10	0.31	0.41	4.97	2.30	0.64	1.28	0.31	1.59	3.79	2.12	0.08	0.17	0.24	0.41
1015GL	5.01	2.35	0.41	0.82	0.31	1.13	6.01	2.70	0.91	1.82	0.31	2.13	5.01	2.35	0.29	0.59	0.54	1.13
1020GL	5.93	3.04	0.37	0.74	0.31	1.05	7.33	3.30	1.07	2.14	0.31	2.45	5.93	3.04	0.39	0.79	0.26	1.05
1025GL	7.39	3.68	0.48	0.96	0.37	1.33	9.11	4.00	1.34	2.68	0.37	3.05	7.39	3.68	0.24	0.49	0.84	1.33
1030GL	8.95	4.26	0.70	1.40	0.37	1.77	10.37	3.60	1.41	2.82	0.37	3.19	8.95	4.26	0.45	0.91	0.86	1.77
1035GL	10.77	4.90	0.97	1.94	0.45	2.39	12.39	4.10	1.78	3.56	0.45	4.01	10.77	4.90	0.55	1.10	1.29	2.39
1040GL	12.61	5.46	1.27	2.54	0.57	3.11	14.27	4.70	2.10	4.20	0.57	4.77	12.61	5.46	0.64	1.28	1.83	3.11
1045GL	13.99	6.08	1.37	2.74	0.63	3.37	15.97	5.10	2.36	4.72	0.63	5.35	13.99	6.08	0.76	1.52	1.85	3.37
1050GL	16.07	6.91	1.65	3.30	0.71	4.01	18.09	5.90	2.66	5.32	0.71	6.03	16.07	6.91	0.81	1.63	2.38	4.01
1055GL	18.51	7.51	2.28	4.56	0.71	5.27	20.09	6.60	3.07	6.14	0.71	6.85	18.51	7.51	0.83	1.66	3.61	5.27
1060GL	19.83	8.33	2.09	4.18	0.83	5.01	22.17	7.20	3.26	6.52	0.83	7.35	19.83	8.33	0.97	1.95	3.06	5.01
1070GL	23.30	9.66	2.44	4.88	1.04	5.92	26.16	8.30	3.87	7.74	1.04	8.78	23.30	9.66	1.06	2.13	3.79	5.92

① See page 12 for General Information.

② Gap discs are not required for Sizes 1010 and 1020GL.

③ Peak torque capacity is two times the published rating.

④ Consult Factory for higher speeds. Balancing may allow up to a 50% increase in speeds shown.

⑤ Maximum bores are reduced for hubs furnished with an interference fit and a setscrew over the keyway. Maximum bores may also be reduced when puller bolt holes are required. Refer to Table 13 and Table 14 on page 38. Bore capacities can be increased beyond values shown if the coupling torque rating is reduced. Refer to the Factory. Recommended key sizes for the listed maximum bores are shown in Table 35, page 48, and Table 23, page 43.

⑥ Minimum bore is the smallest bore to which a Rough Stock Bore (RSB) hub can be bored. Depending upon coupling size, RSB hubs may have only a blind centering hole or a through hole that will permit remachining of the hubs to the minimum bores specified.

**NOTE:** Dimensions subject to change. Certified dimensions of ordered material furnished on request.

# TYPE GL32-1 STANDARD FLANGED SLEEVE SLIDE SINGLE ENGAGEMENT

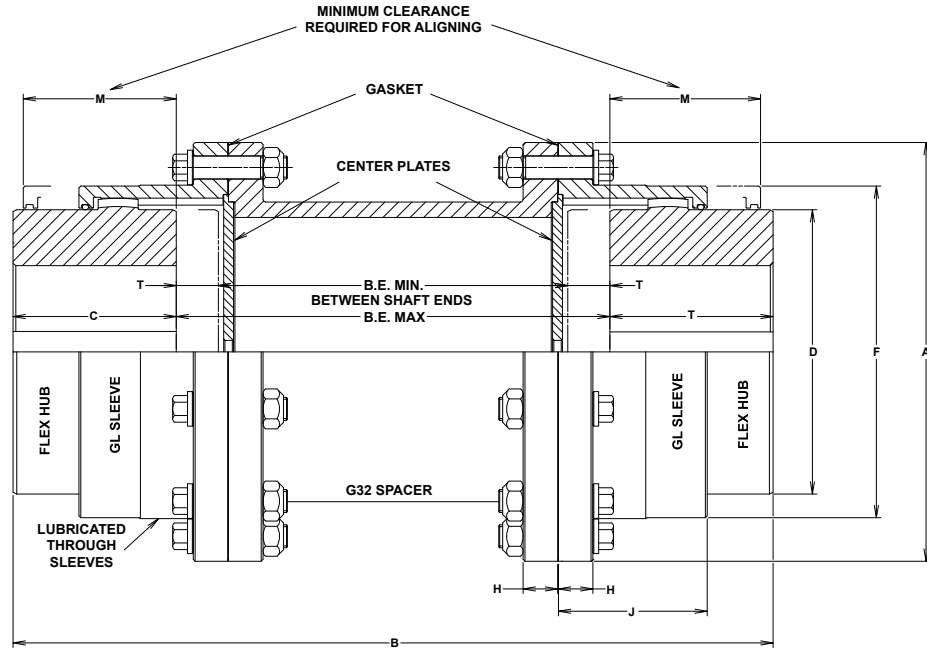

## Dimensions (in)

Size ①	Torque Rating (lb-in) ③	Allow Speed RPM	Max Bore ④	Min Bore ⑤	Cplg Wt Min BE No Bore (lb)	Lube Wt (lb)	A	C	D	F	H	J
1010GL	10,080	5300	1.875	0.5	16	0.05	4.56	1.69	2.70	3.30	0.55	1.53
1015GL	20,790	4300	2.375	0.75	31	0.08	6.00	1.94	3.40	4.14	0.75	1.88
1020GL	37,800	3700	2.875	1.0	47	0.14	7.00	2.44	4.14	4.98	0.75	2.34
1025GL	66,150	3300	3.625	1.25	88	0.25	8.38	3.03	5.14	6.10	0.86	2.82
1030GL	107,100	2900	4.125	1.5	124	0.40	9.44	3.59	6.00	7.10	0.86	3.30
1035GL	163,800	2600	4.875	2.0	200	0.60	11.00	4.19	7.00	8.32	1.12	3.84
1040GL	270,900	2400	5.75	2.5	282	1.00	12.50	4.75	8.25	9.66	1.12	4.38
1045GL	371,700	2100	6.75	3.0	379	1.12	13.63	5.31	9.25	10.79	1.12	4.84
1050GL	500,900	1900	7.375	3.5	547	2.0	15.31	6.03	10.00	12.04	1.50	5.54
1055GL	655,200	1800	8.25	4.0	702	2.5	16.75	6.62	11.00	13.16	1.50	6.22
1060GL	800,100	1600	9.125	4.5	833	3.5	18.00	7.41	12.00	14.41	1.00	6.66
1070GL	1,197,000	1400	10.875	5.0	1311	4.8	20.75	8.69	14.00	16.73	1.12	7.70

Size ①	Type GL32-1				BE Dimensions ②	
	B Max	M	T (Max)		Min	Max
			Each	Total		
1010GL	4.97	2.12	0.05	0.10	3.45	19.90
1015GL	6.01	2.35	0.41	0.82	3.44	19.18
1020GL	7.33	3.04	0.37	0.74	3.44	19.26
1025GL	9.11	3.68	0.48	0.96	3.94	19.04
1030GL	10.37	4.26	0.70	1.40	3.94	18.60
1035GL	12.39	4.90	0.97	1.94	5.00	18.06
1040GL	14.27	5.46	1.27	2.54	5.10	17.46
1045GL	15.97	6.08	1.37	2.74	5.10	17.26
1050GL	18.09	6.91	1.65	3.30	6.18	16.70
1055GL	20.09	7.51	2.28	4.56	6.18	15.44
1060GL	22.17	8.33	2.09	4.18	6.30	15.82
1070GL	26.16	9.66	2.44	4.88	6.44	15.12

- ① See page 12 for General Information.
- ② BE dimension is spacer length plus minimum and maximum GAP values from table above.
- ③ Peak torque capacity is two times the published rating.
- ④ Maximum bores are reduced for hubs furnished with an interference fit and a setscrew over the keyway. Maximum bores may also be reduced when puller bolt holes are required. Refer to Table 13 and Table 14, page 38. Bore capacities can be increased beyond values shown if the coupling torque rating is reduced. Refer to the Factory. Recommended key sizes for the listed maximum bores are shown in Table 35, page 48, and Table 23, page 43.
- ⑤ Minimum bore is the smallest bore to which a Rough Stock Bore (RSB) hub can be bored. Depending upon coupling size, RSB hubs may have only a blind centering hole or a through hole that will permit remachining of the hubs to the minimum bores specified.

NOTE: Dimensions subject to change. Certified dimensions of ordered material furnished on request.

# TYPE GL52 STANDARD FLANGED SLEEVE SLIDE SINGLE ENGAGEMENT

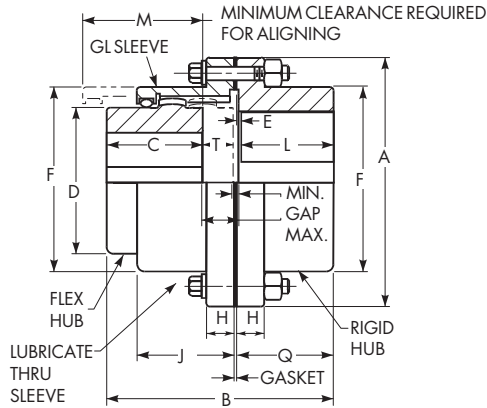

**Type GL52-1 Long Tooth Sleeve  
Reversed Std. Hub**

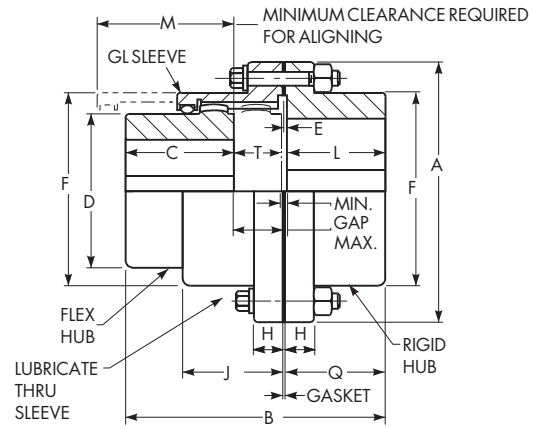

**Type GL52-2 Long Tooth Sleeve  
Cutoff Long Hub**

## Choosing an Assembly

Select the assembly that provides a Total "T" dimension from the table below equal to the application requirements.

- GL52-1 — Moderate slide capacity, moderate price.
- GL52-2 — Greatest slide capacity, highest price.

## Dimensions (in)

Size ①	Torque Rating (lb-in) ②	Allow Speed RPM ③	Max Bore ④		Min Bore ⑤	Cplg Wt with No Bore (lb)	Lube Wt (lb)	A	C	D	E	F	H	J	L	Q
			Flex Hub	Rigid Hub												
1010GL	10,080	5,300	1.875	2.375	0.50	10	0.03	4.56	1.69	2.70	0.10	3.30	0.55	1.53	1.56	1.66
1015GL	20,790	4,300	2.375	2.938	0.75	20	0.05	6.00	1.94	3.40	0.10	4.14	0.75	1.88	1.82	1.92
1020GL	37,800	3,700	2.875	3.625	1.00	35	0.08	7.00	2.44	4.14	0.10	4.98	0.75	2.34	2.30	2.40
1025GL	66,150	3,300	3.625	4.375	1.25	65	0.14	8.38	3.03	5.14	0.10	6.10	0.86	2.82	2.90	3.00
1030GL	107,100	2,900	4.125	5.125	1.50	95	0.25	9.44	3.59	6.00	0.10	7.10	0.86	3.30	3.46	3.56
1035GL	163,800	2,600	4.875	5.875	2.00	150	0.40	11.00	4.19	7.00	0.10	8.32	1.12	3.84	4.02	4.12
1040GL	270,900	2,400	5.750	7.250	2.50	220	0.60	12.50	4.75	8.25	0.16	9.66	1.12	4.38	4.54	4.70
1045GL	371,700	2,100	6.750	8.125	3.00	300	0.75	13.62	5.31	9.25	0.16	10.79	1.12	4.84	5.14	5.30
1050GL	500,900	1,900	7.375	9.000	3.50	430	1.20	15.31	6.03	10.00	0.20	12.04	1.50	5.54	5.80	6.00
1055GL	655,200	1,800	8.250	10.000	4.00	580	1.60	16.75	6.62	11.00	0.20	13.16	1.50	6.22	6.80	7.00
1060GL	800,100	1,600	9.125	11.000	4.50	715	2.12	18.00	7.41	12.00	0.26	14.41	1.00	6.66	7.34	7.60
1070GL	1,197,000	1,400	10.875	13.000	5.00	1125	3.00	20.75	8.69	14.00	0.33	16.73	1.12	7.70	8.67	9.00

Size ①	Type GL52-1						Type GL52-2					
	B Max	M	T Max	GAP		B Max	M	T Max	GAP			
				Min	Max				Min	Max		
1010GL	3.55	2.12	0.14	0.16	0.30	4.14	2.30	0.73	0.16	0.89		
1015GL	4.42	2.35	0.50	0.16	0.66	4.92	2.70	1.00	0.16	1.16		
1020GL	5.36	3.34	0.46	0.16	0.62	6.06	3.30	1.16	0.16	1.32		
1025GL	6.68	3.68	0.57	0.19	0.76	7.55	4.00	1.43	0.19	1.62		
1030GL	8.03	4.26	0.79	0.19	0.98	8.74	3.60	1.50	0.19	1.69		
1035GL	9.50	4.90	1.07	0.22	1.29	10.31	4.10	1.88	0.22	2.10		
1040GL	11.00	5.46	1.43	0.28	1.71	11.83	4.70	2.26	0.28	2.54		
1045GL	12.39	6.08	1.53	0.31	1.84	13.30	5.10	2.52	0.31	2.83		
1050GL	14.02	6.91	1.85	0.34	2.19	15.03	5.90	2.86	0.34	3.20		
1055GL	16.24	7.51	2.48	0.34	2.82	17.03	6.60	3.27	0.34	3.61		
1060GL	17.51	8.33	2.35	0.41	2.76	18.68	7.20	3.52	0.41	3.93		
1070GL	20.63	9.66	2.77	0.50	3.27	22.06	8.30	4.20	0.50	4.70		

① See page 12 for General Information.

② Peak torque capacity is two times the published rating.

③ Consult Factory for higher speeds. Balancing may allow up to a 50% increase in speeds shown.

④ Maximum bores are reduced for hubs furnished with an interference fit and a setscrew over the keyway. Maximum bores may also be reduced when puller bolt holes are required. Refer to Table 13 and Table 14 on page 38. Bore capacities can be increased beyond values shown if the coupling torque rating is reduced. Refer to the Factory. Recommended key sizes for the listed maximum bores are shown in Table 35, page 48, and Table 23, page 43.

⑤ Minimum bore is the smallest bore to which a Rough Stock Bore (RSB) hub can be bored. Depending upon coupling size, RSB hubs may have only a blind centering hole or a through hole that will permit remachining of the hubs to the minimum bores specified.

**NOTE:** Dimensions subject to change. Certified dimensions of ordered material furnished on request.

# TYPE G70 DISCONNECT (INCHING DRIVES)

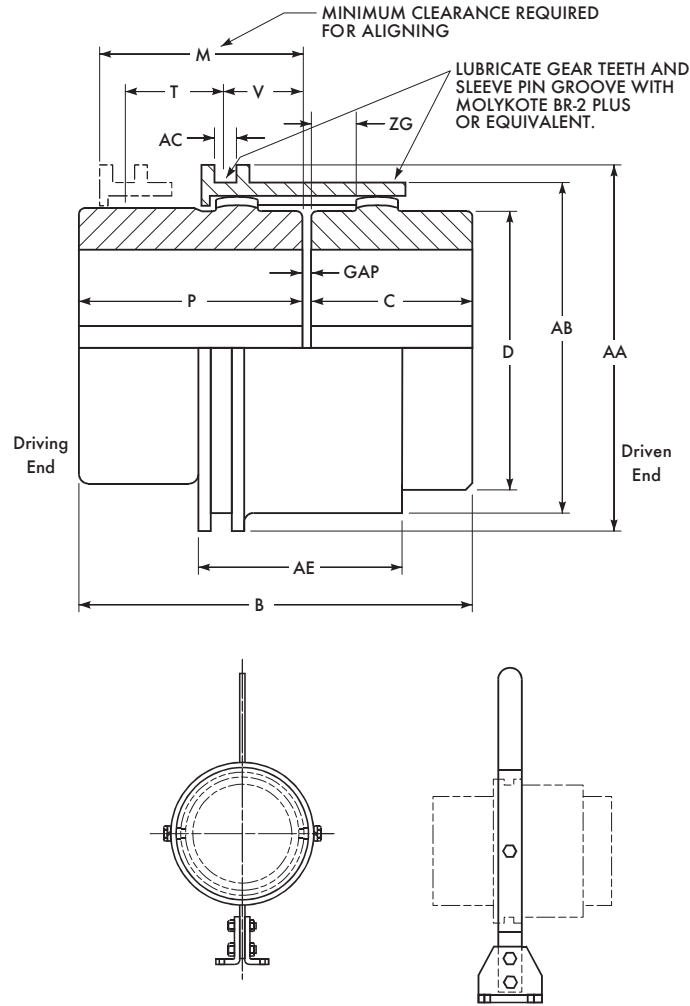

Optional hand-operated shifter mechanism to shift and secure the proper position of the sleeve assembly.

## Dimensions (in)

Size <sup>①</sup>	Torque Rating (lb-in) <sup>②</sup>	Allow Speed RPM <sup>③</sup>	Max Bore <sup>④</sup>	Min Bore <sup>⑤</sup>	Cplg Wt with No Bore (lb)	B	C	D	M	P	T	V	AA	AB	AC	AE	ZG	GAP
1010G	10,080	630	1.875	0.50	9	4.56	1.69	2.70	2.74	2.74	1.18	0.86	3.82	3.30	0.32	2.36	0.58	0.125
1015G	20,790	500	2.375	0.75	15	4.76	1.94	3.40	2.70	2.70	1.16	0.84	4.76	4.23	0.32	2.32	0.50	0.125
1020G	37,800	400	2.875	1.00	30	6.02	2.44	4.14	3.46	3.46	1.50	1.14	5.74	5.10	0.44	3.08	0.70	0.125
1025G	66,150	330	3.625	1.25	53	7.42	3.03	5.14	4.20	4.20	1.90	1.48	6.80	6.16	0.44	3.82	0.86	0.188
1030G	107,100	280	4.125	1.50	80	8.50	3.59	6.00	4.72	4.72	2.16	1.68	7.92	7.16	0.56	4.34	0.96	0.188
1035G	163,800	240	4.875	2.00	123	9.70	4.19	7.00	5.26	5.26	2.48	1.90	9.10	8.35	0.56	4.88	1.06	0.250
1040G	270,900	200	5.750	2.50	183	10.62	4.75	8.25	5.62	5.62	2.66	2.08	10.60	9.85	0.56	5.24	1.08	0.250
1045G	371,700	180	6.750	3.00	262	12.04	5.31	9.25	6.42	6.42	3.04	2.36	11.74	10.85	0.68	6.04	1.24	0.312
1050G	500,900	170	7.375	3.50	353	13.34	6.03	10.00	7.00	7.00	3.32	2.64	13.04	12.16	0.68	6.60	1.37	0.312
1055G	655,200	150	8.250	4.00	439	14.04	6.62	11.00	7.10	7.10	3.38	2.68	14.04	13.16	0.68	6.70	1.29	0.312
1060G	800,100	140	9.125	4.50	603	16.02	7.41	12.00	8.30	8.30	3.94	3.22	15.62	14.41	0.76	7.92	1.67	0.312
1070G	1,197,000	120	10.875	5.00	935	18.36	8.69	14.00	9.40	9.30	4.60	3.67	17.94	16.73	0.76	9.03	1.96	0.375

① See page 12 for General Information.

② Peak torque capacity is two times the published rating.

③ Consult Factory for higher speeds. Balancing may allow up to a 50% increase in speeds shown.

④ Maximum bores are reduced for hubs furnished with an interference fit and a setscrew over the keyway. Maximum bores may also be reduced when puller bolt holes are required. Refer to Table 13 and Table 14 on page 38. Bore capacities can be increased beyond values shown if the coupling torque rating is reduced. Refer to the Factory. Recommended key sizes for the listed maximum bores are shown in Table 35, page 48, and Table 23, page 43.

⑤ Minimum bore is the smallest bore to which a Rough Stock Bore (RSB) hub can be bored. Depending upon coupling size, RSB hubs may have only a blind centering hole or a through hole that will permit remachining of the hubs to the minimum bores specified.

**NOTE:** Dimensions subject to change. Certified dimensions of ordered material furnished on request.

# TYPE G72 DISCONNECT

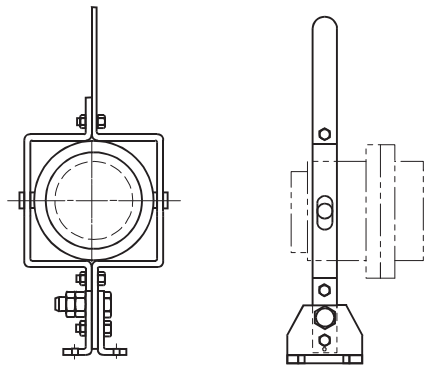
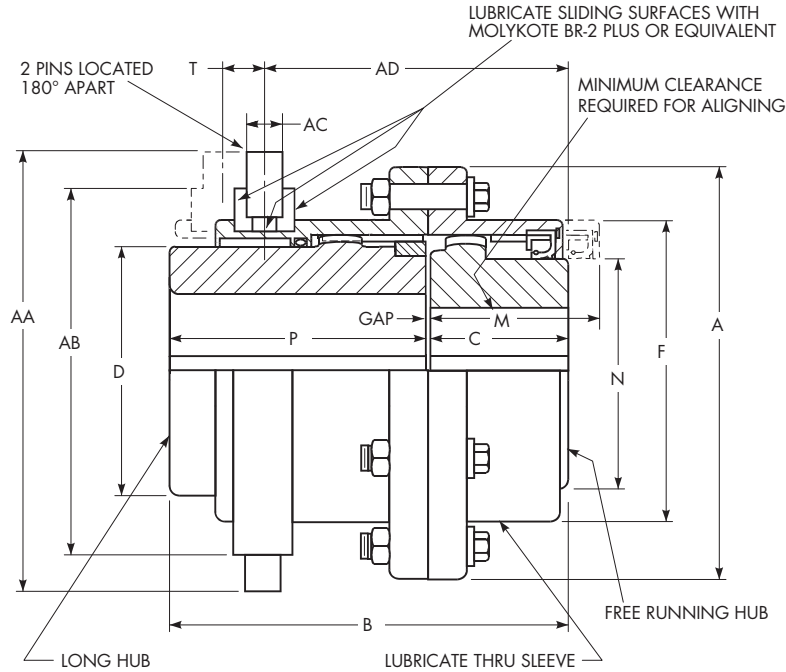

Optional hand-operated shifter mechanism to shift and secure the proper position of the sleeve assembly.

## Dimensions (in)

Size ①	Torque Rating (lb-in) ②	Allow Speed RPM ③	Max Bore ④		Min Bore ⑤	Cplg Wt with No Bore (lb)	Lube Wt (lb)	A	B	C	D	F	M	N	P	T	AA	AB	AC	AD	GAP
			Long Hub	Free Hub																	
1010G	10,080	4,200	1.875	1.500	0.50	15	0.07	4.56	5.06	1.68	2.70	3.30	2.30	2.25	3.25	0.50	6.25	5.00	0.62	3.68	0.125
1015G	20,790	3,200	2.375	2.062	0.75	29	0.12	6.00	5.81	2.06	3.40	4.14	3.00	3.00	3.62	0.56	7.25	6.00	0.62	4.26	0.125
1020G	37,800	2,450	2.875	2.688	1.00	50	0.20	7.00	7.06	2.44	4.14	4.98	3.30	3.88	4.50	0.88	7.75	6.50	0.62	5.38	0.125
1025G	66,150	2,000	3.625	3.250	1.25	79	0.38	8.38	8.44	2.88	5.14	6.10	3.60	4.75	5.38	0.88	9.00	7.50	0.75	6.50	0.188
1030G	107,100	1,650	4.125	4.000	1.50	115	0.60	9.44	9.68	3.88	6.00	7.10	4.20	5.75	5.62	1.00	9.75	8.50	0.88	7.86	0.188
1035G	163,800	1,530	4.875	4.312	2.00	180	0.90	11.00	10.88	4.00	7.00	8.32	4.10	6.25	6.62	1.12	11.88	10.62	0.88	8.64	0.250
1040G	270,900	1,200	5.750	5.562	2.50	267	1.50	12.50	12.05	4.42	8.25	9.66	4.90	8.00	7.38	1.25	13.88	11.62	1.00	9.66	0.250
1045G	371,700	1,060	6.750	6.188	3.00	336	1.70	13.62	12.38	4.82	9.25	10.79	5.50	8.88	7.25	1.56	15.50	13.00	1.00	9.91	0.312
1050G	500,900	950	7.375	7.375	3.50	461	3.00	15.31	14.19	5.62	10.00	12.04	7.20	10.00	8.25	1.75	15.00	12.75	1.00	11.16	0.312
1055G	655,200	860	8.250	7.375	4.00	612	3.70	16.75	15.19	6.62	11.00	13.16	7.25	10.00	8.25	2.12	17.75	15.75	1.12	13.31	0.312
1060G	800,100	830	9.125	8.625	4.50	809	5.25	18.00	18.31	7.12	12.00	14.41	7.62	11.50	10.88	2.00	18.25	16.62	1.12	14.56	0.312
1070G	1,197,000	680	10.875	10.875	5.00	1155	7.20	20.75	18.88	7.75	14.00	16.73	10.50	14.00	10.75	2.25	23.00	20.00	1.12	15.08	0.375

① See page 12 for General Information.

② Peak torque capacity is two times the published rating.

③ Consult Factory for higher speeds. Balancing may allow up to a 50% increase in speeds shown.

④ Maximum bores are reduced for hubs furnished with an interference fit and a setscrew over the keyway. Maximum bores may also be reduced when puller bolt holes are required. Refer to Table 13 and Table 14 on page 38. Bore capacities can be increased beyond values shown if the coupling torque rating is reduced. Refer to the Factory. Recommended key sizes for the listed maximum bores are shown in Table 35, page 48, and Table 23, page 43.

⑤ Minimum bore is the smallest bore to which a Rough Stock Bore (RSB) hub can be bored. Depending upon coupling size, RSB hubs may have only a blind centering hole or a through hole that will permit remachining of the hubs to the minimum bores specified.

**NOTE:** Dimensions subject to change. Certified dimensions of ordered material furnished on request.

# TYPE G82 STANDARD FLANGED SLEEVE RIGID

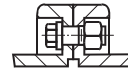
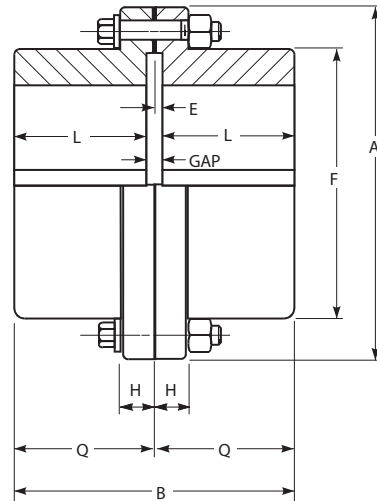

For Sizes 1010G thru 1055G,  
Type G81 Shrouded bolts furnished  
only when specified on the order.

## Dimensions (in)

Size ①	Torque Rating (lb-in) ②	Allow Speed RPM ③	Max Bore ④	Min Bore ⑤	Cplg Wt with No Bore (lb)		A	B	E	F	H	L	Q	GAP
					G81	G82								
1010G	10,080	8,000	2.375	0.50	9	10	4.56	3.32	0.10	3.30	0.55	1.56	1.66	0.200
1015G	20,790	6,500	2.938	0.75	19	20	6.00	3.84	0.10	4.14	0.75	1.82	1.92	0.200
1020G	37,800	5,600	3.625	1.00	30	35	7.00	4.80	0.10	4.98	0.75	2.30	2.40	0.200
1025G	66,150	5,000	4.375	1.25	55	60	8.38	6.00	0.10	6.10	0.86	2.90	3.00	0.200
1030G	107,100	4,400	5.125	1.50	90	95	9.44	7.12	0.10	7.10	0.86	3.46	3.56	0.200
1035G	163,800	3,900	5.875	2.00	135	155	11.00	8.24	0.10	8.32	1.12	4.02	4.12	0.200
1040G	270,900	3,600	7.250	2.50	210	225	12.50	9.40	0.16	9.66	1.12	4.54	4.70	0.320
1045G	371,700	3,200	8.125	3.00	290	310	13.62	10.60	0.16	10.79	1.12	5.14	5.30	0.320
1050G	500,900	2,900	9.000	3.50	415	450	15.31	12.00	0.20	12.04	1.50	5.80	6.00	0.400
1055G	655,200	2,650	10.000	4.00	590	620	16.75	14.00	0.20	13.16	1.50	6.80	7.00	0.400
1060G	800,100	2,450	11.000	4.50	—	740	18.00	15.20	0.26	14.41	1.00	7.34	7.60	0.520
1070G	1,197,000	2,150	13.000	5.00	—	1180	20.75	18.00	0.33	16.73	1.12	8.67	9.00	0.660

① See page 12 for General Information.

② Peak torque capacity is two times the published rating.

③ Consult Factory for higher speeds. Balancing may allow up to a 50% increase in speeds shown.

④ Maximum bores are reduced for hubs furnished with an interference fit and a setscrew over the keyway. Maximum bores may also be reduced when puller bolt holes are required. Refer to **Table 13 and Table 14 on page 38**. Bore capacities can be increased beyond values shown if the coupling torque rating is reduced. Refer to the Factory. Recommended key sizes for the listed maximum bores are shown in **Table 35, page 48**, and **Table 23, page 43**.

⑤ Minimum bore is the smallest bore to which a Rough Stock Bore (RSB) hub can be bored. Depending upon coupling size, RSB hubs may have only a blind centering hole or a through hole that will permit remachining of the hubs to the minimum bores specified.

**NOTE:** Dimensions subject to change. Certified dimensions of ordered material furnished on request.

# TYPE GV82 STANDARD FLANGED SLEEVE RIGID THRUST

Type GV82 couplings are used as rigid connections for the low-speed shaft of a gear drive and a mixer shaft or suspended load. The coupling carries the torque load, weight of the shaft and impeller, thrust forces and resulting bending moments.

When a rigid coupling is required, the following additional information is necessary.

1. Required thrust capacity and direction of thrust.
2. Radial force at impeller.
3. Distance from the center of coupling fastener flange to the center of the impeller.
4. Weight of shaft and impeller.

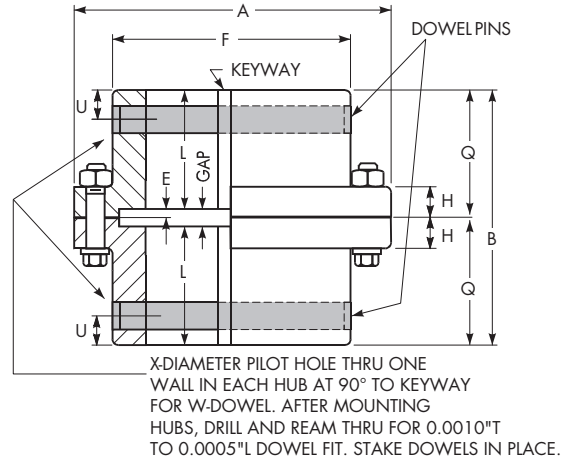
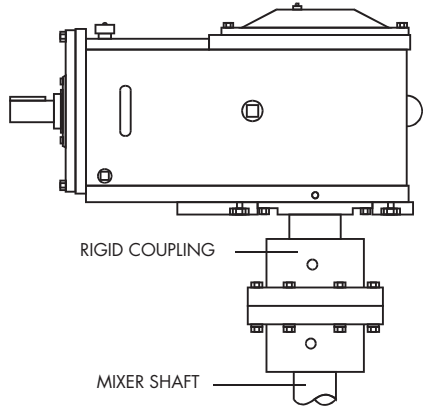

## Dimensions (in)

Size ①	Torque Rating (lb-in) ③	Hub Bore Range ④	Cplg Wt with No Bore (lb)	A	B	E	F	H	L	Q	U	W ②		X	GAP
												Dowel Dia x Length	Dowel Hole-Dia +.0005 -.0000		
1010GV	10,080	1.375-2.250	10	4.56	3.32	0.10	3.30	0.55	1.56	1.66	0.38	0.375 x 3.22	0.3740	0.344	0.200
1015GV	20,790	1.625-2.750	20	6.00	3.84	0.10	4.14	0.75	1.82	1.92	0.50	0.500 x 4.06	0.4990	0.469	0.200
1020GV	37,800	2.500-3.250	35	7.00	4.80	0.10	4.98	0.75	2.30	2.40	0.75	0.750 x 4.88	0.7490	0.719	0.200
1025GV	66,150	3.250-4.000	60	8.38	6.00	0.10	6.10	0.86	2.90	3.00	1.00	1.000 x 5.98	0.9990	0.938	0.200
1030GV	107,100	3.500-4.500	95	9.44	7.12	0.10	7.10	0.86	3.46	3.56	1.12	1.125 x 6.96	1.1240	1.063	0.200
1035GV	163,800	4.000-5.250	155	11.00	8.24	0.10	8.32	1.12	4.02	4.12	1.25	1.250 x 8.20	1.2490	1.188	0.200
1040GV	270,900	4.500-6.250	225	12.50	9.40	0.16	9.66	1.12	4.54	4.70	1.38	1.375 x 9.52	1.3740	1.313	0.320
1045GV	371,700	5.000-7.000	310	13.62	10.60	0.16	10.79	1.12	5.14	5.30	1.50	1.500 x 10.64	1.4990	1.438	0.320
1050GV	500,900	5.750-7.750	450	15.31	12.00	0.20	12.04	1.50	5.80	6.00	1.75	1.750 x 11.86	1.7490	1.688	0.400
1055GV	655,200	5.750-8.500	620	16.75	14.00	0.20	13.16	1.50	6.80	7.00	1.75	1.750 x 13.00	1.7490	1.688	0.400
1060GV	800,100	6.750-9.250	740	18.00	15.20	0.26	14.41	1.00	7.34	7.60	2.00	2.000 x 14.22	1.9990	1.938	0.520
1070GV	1,197,000	6.750-10.750	1180	20.75	18.00	0.33	16.73	1.12	8.67	9.00	2.00	2.000 x 16.56	1.9990	1.938	0.660

① See page 12 for General Information.

② Dowels: diameters, +.000", -.001" material, AISI 4140 hardness, 310-350 HB; furnished by the Factory. Customer is responsible for checking and furnishing driven shaft with satisfactory capacity.

③ Peak torque capacity is two times the published rating.

④ Maximum bores are reduced for hubs furnished with an interference fit and a setscrew over the keyway. Maximum bores may also be reduced when puller bolt holes are required. Refer to Table 13 and Table 14 on page 38. Bore capacities can be increased beyond values shown if the coupling torque rating is reduced. Refer to the Factory. Recommended key sizes for the listed maximum bores are shown in Table 35, page 48, and Table 23, page 43.

**NOTE:** Dimensions subject to change. Certified dimensions of ordered material furnished on request.

# TYPE G20 LARGE FLANGED SLEEVE DOUBLE ENGAGEMENT

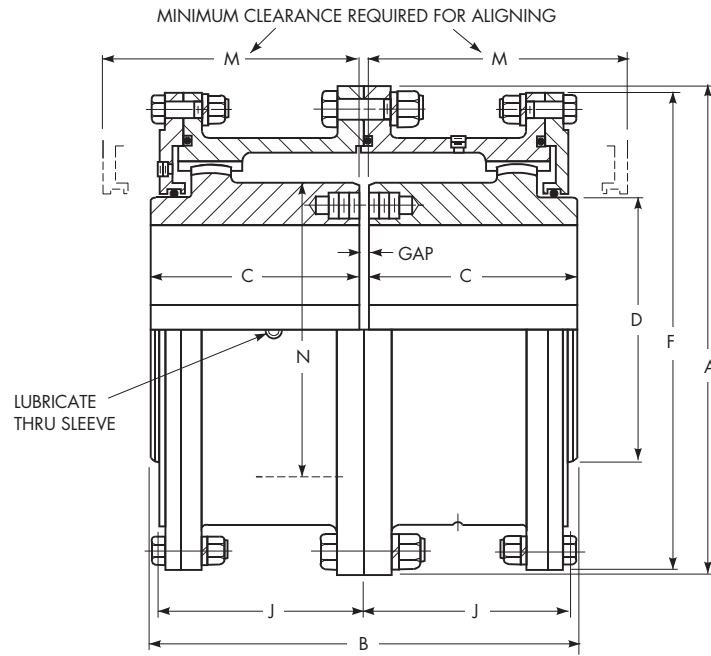

## Dimensions (in)

Size ①	Torque Rating (lb-in – millions) ③		Allow Speed RPM ④	Max Bore One Rect Key ⑤	Min Bore ⑥	Cplg Wt with No Bore (lb)	Lube Wt (lb)	A	B	C	D	F	J	M	N	GAP
	1000 Series	2000 Series														
1080/2080G	1.506	2.070	1,750	10.50	4.000	1550	21	23.25	20.02	9.82	14.00	22.50	9.56	11.81	14.50	0.375
1090/2090G	1.997	2.791	1,550	11.25	4.500	2170	27	26.00	22.26	10.88	15.50	25.25	10.44	12.88	16.50	0.500
1100/2100G	2.747	3.919	1,450	12.75	5.000	2870	33	28.00	24.50	12.00	17.50	27.50	11.56	14.00	18.50	0.500
1110/2110G	3.654	5.393	1,330	14.00	5.500	3700	39	30.50	26.74	13.12	19.50	29.50	12.69	15.12	20.50	0.500
1120/2120G	4.914	6.880	1,200	15.25	6.000	4660	46	33.00	28.26	13.88	21.50	32.50	13.44	15.88	22.50	0.500
1130/2130G	6.363	8.190	1,075	16.25	6.500	5720	72	35.88	29.99	14.62	23.00	34.88	14.25	17.12	24.00	0.750
1140/2140G	8.064	10.080	920	17.75	7.000	6850	73	38.00	31.71	15.48	25.00	37.00	14.88	18.00	26.00	0.750
1150/2150G	9.702	11.970	770	19.00	7.500	8300	90	40.50	33.75	16.50	27.00	39.50	16.06	19.00	28.00	0.750
1160/2160G	11.592	14.490	650	21.00 ②	10.000	10380	95	43.75	35.75	17.375	29.00	42.75	16.50	19.75	30.00 ②	1.000
1180/2180G	14.679	18.900	480	24.25 ②	11.250	13800	110	48.00	37.00	18.00	33.00	47.00	17.12	20.50	34.00 ②	1.000
1200/2200G	18.963	25.200	370	27.00 ②	12.500	18920	150	53.50	43.25	21.125	36.50	51.50	20.25	25.00	38.00 ②	1.000
1220/2220G	24.066	31.500	290	30.00 ②	13.750	25760	235	59.50	47.00	23.00	40.00	58.00	22.25	27.00	42.00 ②	1.000
1240/2240G	30.744	39.690	270	33.75 ②	15.000	32200	240	64.25	50.50	24.75	44.50	62.25	23.88	28.50	46.00 ②	1.000
1260/2260G	39.753	48.510	250	37.00 ②	16.250	39240	270	68.75	54.00	26.50	48.50	66.75	25.50	30.50	50.00 ②	1.000
1280/2280G	51.660	59.850	230	39.00 ②	17.500	46720	300	73.50	55.48	27.24	52.50	71.00	26.25	31.25	54.00 ②	1.000
1300/2300G	59.850	72.450	220	42.00 ②	18.750	54690	330	77.75	57.00	28.00	56.50	75.25	27.00	31.50	58.00 ②	1.000

- ① See page 12 for General Information.
- ② Reduced shank diameter hubs are available where required bore permits. See Table 32, page 46 for selection.
- ③ Peak torque capacity is two times the published rating.
- ④ Consult Factory for higher speeds. Balancing may allow up to a 50% increase in speeds shown.
- ⑤ Maximum bores are reduced for hubs furnished with an interference fit and a setscrew over the keyway. Maximum bores may also be reduced when puller bolt holes are required. Refer to Table 13 and Table 14 on page 38. Bore capacities can be increased beyond values shown if the coupling torque rating is reduced. Refer to the Factory. Recommended key sizes for the listed maximum bores are shown in Table 35, page 48, and Table 23, page 43.
- ⑥ Minimum bore is the smallest bore to which a Rough Stock Bore (RSB) hub can be bored. Depending upon coupling size, RSB hubs may have only a blind centering hole or a through hole that will permit remachining of the hubs to the minimum bores specified.

**NOTE:** Dimensions subject to change. Certified dimensions of ordered material furnished on request.

# TYPE G52 LARGE FLANGED SLEEVE SINGLE ENGAGEMENT

**IMPORTANT:** When couplings are mounted on a floating shaft, do not exceed allowable shaft speed for the assembly. Use a gap disc in each coupling.

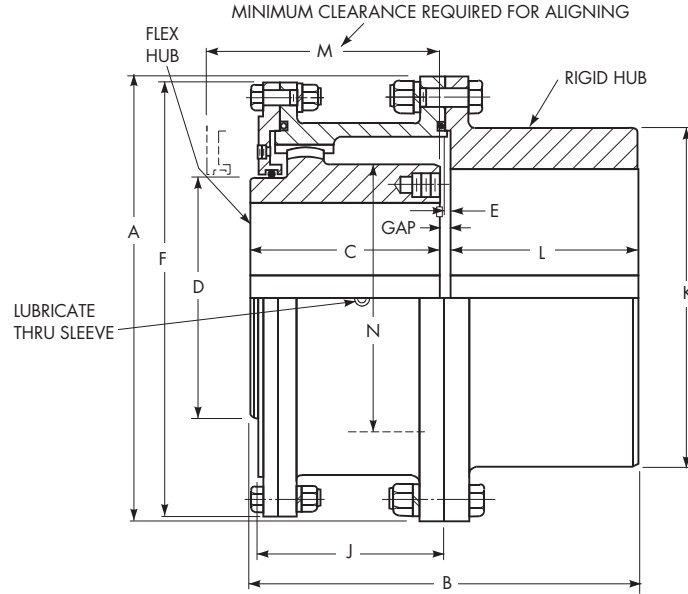

## Dimensions (in)

Size ①	Torque Rating (lb-in – millions) ④		Allow Speed RPM ⑤	Max Bore One Rect Key ⑥		Min Bore ⑦	Cplg Wt with No Bore(lb)	Lube Wt (lb)	A	B	C	D	E	F	J	K ③	L	M	N	GAP
	1000 Series	2000 Series		Flex Hub	Rigid Hub															
1080/2080G	1.506	2.070	1,750	10.50	13.25	4.000	1540	11	23.25	20.12	9.82	14.00	0.32	22.50	9.56	17.75	9.80	11.81	14.50	0.50
1090/2090G	1.997	2.791	1,550	11.25	15.00	4.500	2170	14	26.00	22.30	10.88	15.50	0.32	25.25	10.44	20.00	10.86	12.88	16.50	0.56
1100/2100G	2.747	3.919	1,450	12.75	15.50	5.000	2760	17	28.00	24.62	12.00	17.50	0.38	27.50	11.56	20.88	12.00	14.00	18.50	0.62
1110/2110G	3.654	5.393	1,330	14.00	17.25	5.500	3610	20	30.50	26.86	13.12	19.50	0.38	29.50	12.69	23.00	13.12	15.12	20.50	0.62
1120/2120G	4.914	6.880	1,200	15.25	19.00	6.000	4580	24	33.00	28.37	13.88	21.50	0.38	32.50	13.44	25.50	13.87	15.88	22.50	0.62
1130/2130G	6.363	8.190	1,075	16.25	20.75	6.500	5670	37	35.88	29.99	14.62	23.00	0.38	34.88	14.25	27.88	14.62	17.12	24.00	0.75
1140/2140G	8.064	10.080	920	17.75	22.00	7.000	6750	38	38.00	31.73	15.48	25.00	0.38	37.00	14.88	29.50	15.50	18.00	26.00	0.75
1150/2150G	9.702	11.970	770	19.00	24.00	7.500	8270	46	40.50	33.75	16.50	27.00	0.38	39.50	16.06	32.00	16.50	19.00	28.00	0.75
1160/2160G	11.592	14.490	650	21.00 ②	26.00 ②	10.000	10210	48	43.75	35.76	17.375	29.00	0.50	42.75	16.50	34.88 ②	17.38	19.75	30.00 ②	1.00
1180/2180G	14.679	18.900	480	24.25 ②	30.00 ②	11.250	13380	56	48.00	37.00	18.00	33.00	0.50	47.00	17.12	39.12 ②	18.00	20.50	34.00 ②	1.00
1200/2200G	18.963	25.200	370	27.00 ②	33.25 ②	12.500	18700	76	53.50	43.25	21.125	36.50	0.50	51.50	20.25	43.12 ②	21.12	25.00	38.00 ②	1.00
1220/2220G	24.066	31.500	290	30.00 ②	38.00 ②	13.750	25750	120	59.50	47.12	23.00	40.00	0.62	58.00	22.25	49.00 ②	23.00	27.00	42.00 ②	1.12
1240/2240G	30.744	39.690	270	33.75 ②	40.00 ②	15.000	31720	125	64.25	50.62	24.75	44.50	0.62	62.25	23.88	51.76 ②	24.75	28.50	46.00 ②	1.12
1260/2260G	39.753	48.510	250	37.00 ②	43.50 ②	16.250	39070	135	68.75	54.12	26.50	48.50	0.62	66.75	25.50	56.00 ②	26.50	30.50	50.00 ②	1.12
1280/2280G	51.660	59.850	230	39.00 ②	46.25 ②	17.500	46540	155	73.50	55.60	27.24	52.50	0.62	71.00	26.25	60.26 ②	27.24	31.25	54.00 ②	1.12
1300/2300G	59.850	72.450	220	42.00 ②	50.00 ②	18.750	54480	170	77.75	57.12	28.00	56.50	0.62	75.25	27.00	64.50 ②	28.00	31.50	58.00 ②	1.12

- ① See page 12 for General Information.
- ② Reduced shank diameter hubs are available where required bore permits. See Table 32, page 46 for selection.
- ③ Dimension K may be an "as-cast" surface, depending upon coupling size and bore.
- ④ Peak torque capacity is two times the published rating.
- ⑤ Consult Factory for higher speeds. Balancing may allow up to a 50% increase in speeds shown.
- ⑥ Maximum bores are reduced for hubs furnished with an interference fit and a setscrew over the keyway. Maximum bores may also be reduced when puller bolt holes are required. Refer to Table 13 and Table 14 on page 38. Bore capacities can be increased beyond values shown if the coupling torque rating is reduced. Refer to the Factory. Recommended key sizes for the listed maximum bores are shown in Table 35, page 48, and Table 23, page 43.
- ⑦ Minimum bore is the smallest bore to which a Rough Stock Bore (RSB) hub can be bored. Depending upon coupling size, RSB hubs may have only a blind centering hole or a through hole that will permit remachining of the hubs to the minimum bores specified.

**NOTE:** Dimensions subject to change. Certified dimensions of ordered material furnished on request.

# TYPE G52 LARGE FLANGED SLEEVE SINGLE ENGAGEMENT (Cont.)

## Floating Shaft

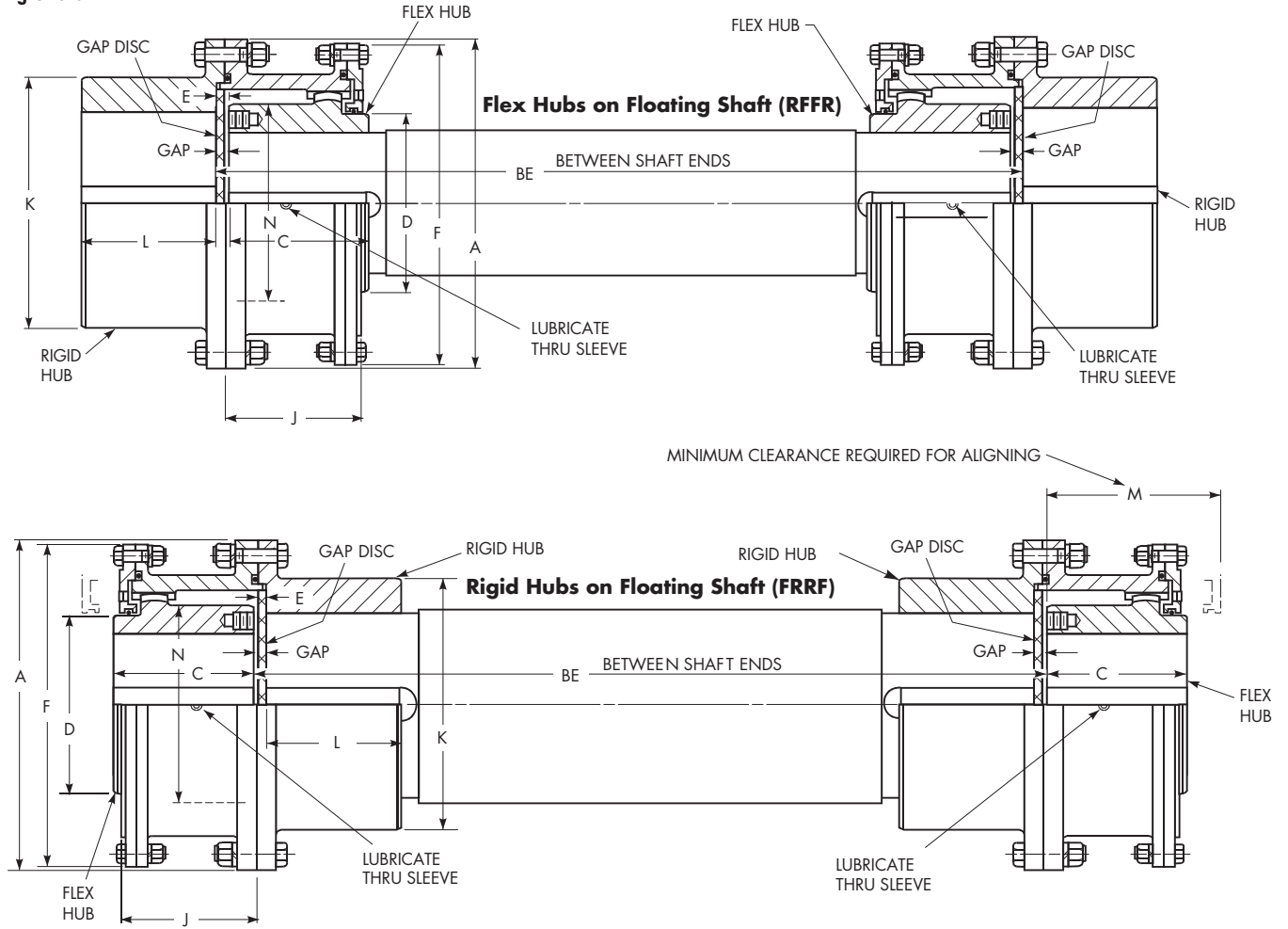

## Dimensions (in)

Size ①	Torque Rating (lb-in – millions) ⑤		Allow Speed RPM ④	Max Bore One Rect Key ⑥		Cplg Wt with No Bore (lb)	Lube Wt (lb)	A	BE Min		C	D	E	F	J	K ③	L	M	N	GAP
	1000 Series	2000 Series		Flex Hub	Rigid Hub				RFFR	FRRF										
1080/2080G	1.506	2.070	1,300	10.50	13.25	1540	11	23.25	30.50	21.62	9.82	14.00	0.32	22.50	9.56	17.75	9.80	11.81	14.50	0.50
1090/2090G	1.997	2.791	1,160	11.25	15.00	2170	14	26.00	32.50	23.88	10.88	15.50	0.32	25.25	10.44	20.00	10.86	12.88	16.50	0.56
1100/2100G	2.747	3.919	1,090	12.75	15.50	2760	17	28.00	36.50	26.25	12.00	17.50	0.38	27.50	11.56	20.88	12.00	14.00	18.50	0.62
1110/2110G	3.654	5.393	1,000	14.00	17.25	3610	20	30.50	40.50	28.50	13.12	19.50	0.38	29.50	12.69	23.00	13.12	15.12	20.50	0.62
1120/2120G	4.914	6.880	900	15.25	19.00	4580	24	33.00	43.50	30.00	13.88	21.50	0.38	32.50	13.44	25.50	13.87	15.88	22.50	0.62
1130/2130G	6.363	8.190	800	16.25	20.75	5670	37	35.88	44.50	31.75	14.62	23.00	0.38	34.88	14.25	27.88	14.62	17.12	24.00	0.75
1140/2140G	8.064	10.080	700	17.75	22.00	6750	38	38.00	46.50	33.50	15.48	25.00	0.38	37.00	14.88	29.50	15.50	18.00	26.00	0.75
1150/2150G	9.702	11.970	580	19.00	24.00	8270	46	40.50	51.00	35.50	16.50	27.00	0.38	39.50	16.06	32.00	16.50	19.00	28.00	0.75
1160/2160G	11.592	14.490	490	21.00 ②	26.00 ②	10210	48	43.75	52.00	37.75	17.38	29.00	0.50	42.75	16.50	34.88 ②	17.38	19.75	30.00 ②	1.00
1180/2180G	14.679	18.900	360	24.25 ②	30.00 ②	13380	56	48.00	53.50	39.00	18.00	33.00	0.50	47.00	17.12	39.12 ②	18.00	20.50	34.00 ②	1.00
1200/2200G	18.963	25.200	280	27.00 ②	33.25 ②	18700	76	53.50	65.00	45.25	21.12	36.50	0.50	51.50	20.25	43.12 ②	21.12	25.00	38.00 ②	1.00
1220/2220G	24.066	31.500	220	30.00 ②	38.00 ②	25750	120	59.50	72.00	49.25	23.00	40.00	0.62	58.00	22.25	49.00 ②	23.00	27.00	42.00 ②	1.12
1240/2240G	30.744	39.690	200	33.75 ②	40.00 ②	31720	125	64.25	78.50	52.75	24.75	44.50	0.62	62.25	23.88	51.76 ②	24.75	28.50	46.00 ②	1.12
1260/2260G	39.753	48.510	190	37.00 ②	43.50 ②	39070	135	68.75	85.00	56.25	26.50	48.50	0.62	66.75	25.50	56.00 ②	26.50	30.50	50.00 ②	1.12
1280/2280G	51.660	59.850	175	39.00 ②	46.25 ②	46540	155	73.50	87.50	57.25	27.24	52.50	0.62	71.00	26.25	60.26 ②	27.24	31.25	54.00 ②	1.12
1300/2300G	59.850	72.450	165	42.00 ②	50.00 ②	54480	170	77.75	90.00	59.25	28.00	56.50	0.62	75.25	27.00	64.50 ②	28.00	31.50	58.00 ②	1.12

- ① See page 12 for General Information.
- ② Reduced shank diameter hubs are available where required bore permits. See Table 32, page 46 for selection.
- ③ Dimension K may be an "as-cast" surface, depending upon coupling size and bore.
- ④ The allowable speed for floating shaft assemblies is the smaller value of either the critical speed of the selected shaft or the cataloged speed of the selected size coupling. The allowable operating speed should be based on torque, misalignment, balance and other operating requirements for the specific application. If higher speeds are required or special application requirements must be met, consult the Factory for assistance.
- ⑤ Peak torque capacity is two times the published rating.
- ⑥ Maximum bores are reduced for hubs furnished with an interference fit and a setscrew over the keyway. Maximum bores may also be reduced when puller bolt holes are required. Refer to Table 13 and Table 14 on page 38. Bore capacities can be increased beyond values shown if the coupling torque rating is reduced. Refer to the Factory. Recommended key sizes for the listed maximum bores are shown in Table 35, page 48, and Table 23, page 43.

NOTE: Dimensions subject to change. Certified dimensions of ordered material furnished on request.

# TYPE GV20 LARGE FLANGED SLEEVE VERTICAL DOUBLE ENGAGEMENT

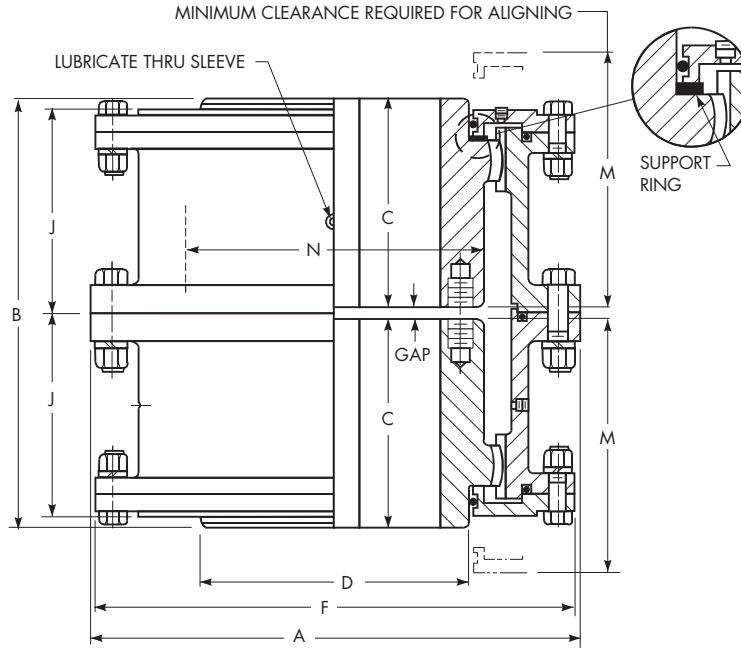

## Dimensions (in)

Size ①	Torque Rating (lb-in – millions) ③		Allow Speed RPM ④	Max Bore One Rect Key ⑤	Min Bore ⑥	Cplg Wt with No Bore (lb)	Lube Wt (lb)	A	B	C	D	F	J	M	N	GAP
	1000 Series	2000 Series														
1080/2080GV	1.506	2.070	1,750	10.50	4.000	1550	21	23.25	20.02	9.82	14.00	22.50	9.56	11.81	14.50	0.375
1090/2090GV	1.997	2.791	1,550	11.25	4.500	2170	27	26.00	22.26	10.88	15.50	25.25	10.44	12.88	16.50	0.500
1100/2100GV	2.747	3.919	1,450	12.75	5.000	2870	33	28.00	24.50	12.00	17.50	27.50	11.56	14.00	18.50	0.500
1110/2110GV	3.654	5.393	1,330	14.00	5.500	3700	39	30.50	26.74	13.12	19.50	29.50	12.69	15.12	20.50	0.500
1120/2120GV	4.914	6.880	1,200	15.25	6.000	4660	46	33.00	28.26	13.88	21.50	32.50	13.44	15.88	22.50	0.500
1130/2130GV	6.363	8.190	1,075	16.25	6.500	5720	72	35.88	29.99	14.62	23.00	34.88	14.25	17.12	24.00	0.750
1140/2140GV	8.064	10.080	920	17.75	7.000	6850	73	38.00	31.71	15.48	25.00	37.00	14.88	18.00	26.00	0.750
1150/2150GV	9.702	11.970	770	19.00	7.500	8300	90	40.50	33.75	16.50	27.00	39.50	16.06	19.00	28.00	0.750
1160/2160GV	11.592	14.490	650	21.00 ②	10.000	10380	95	43.75	35.75	17.38	29.00	42.75	16.50	19.75	30.00 ②	1.000
1180/2180GV	14.679	18.900	480	24.25 ②	11.250	13800	110	48.00	37.00	18.00	33.00	47.00	17.12	20.50	34.00 ②	1.000
1200/2200GV	18.963	25.200	370	27.00 ②	12.500	18920	150	53.50	43.25	21.12	36.50	51.50	20.25	25.00	38.00 ②	1.000
1220/2220GV	24.066	31.500	290	30.00 ②	13.750	25760	235	59.50	47.00	23.00	40.00	58.00	22.25	27.00	42.00 ②	1.000
1240/2240GV	30.744	39.690	270	33.75 ②	15.000	32200	270	64.25	50.50	24.75	44.50	62.25	23.88	28.50	46.00 ②	1.000
1260/2260GV	39.753	48.510	250	37.00 ②	16.250	39240	270	68.75	54.00	26.50	48.50	66.75	25.50	30.50	50.00 ②	1.000
1280/2280GV	51.660	59.850	230	39.00 ②	17.500	46720	300	73.50	55.48	27.24	52.50	71.00	26.25	31.25	54.00 ②	1.000
1300/2300GV	59.850	72.450	220	42.00 ②	18.750	54690	330	77.75	57.00	28.00	56.50	75.25	27.00	31.50	58.00 ②	1.000

- ① See page 12 for General Information.
- ② Reduced shank diameter hubs are available where required bore permits. See Table 32, page 46 for selection.
- ③ Peak torque capacity is two times the published rating.
- ④ Consult Factory for higher speeds. Balancing may allow up to a 50% increase in speeds shown.
- ⑤ Maximum bores are reduced for hubs furnished with an interference fit and a setscrew over the keyway. Maximum bores may also be reduced when puller bolt holes are required. Refer to Table 13 and Table 14 on page 38. Bore capacities can be increased beyond values shown if the coupling torque rating is reduced. Refer to the Factory. Recommended key sizes for the listed maximum bores are shown in Table 35, page 48, and Table 23, page 43.
- ⑥ Minimum bore is the smallest bore to which a Rough Stock Bore (RSB) hub can be bored. Depending upon coupling size, RSB hubs may have only a blind centering hole or a through hole that will permit remachining of the hubs to the minimum bores specified.

**NOTE:** Dimensions subject to change. Certified dimensions of ordered material furnished on request.

# TYPE GV52 LARGE FLANGED SLEEVE VERTICAL SINGLE ENGAGEMENT

**IMPORTANT:** When couplings are mounted on a floating shaft, do not exceed allowable shaft speed for the assembly.

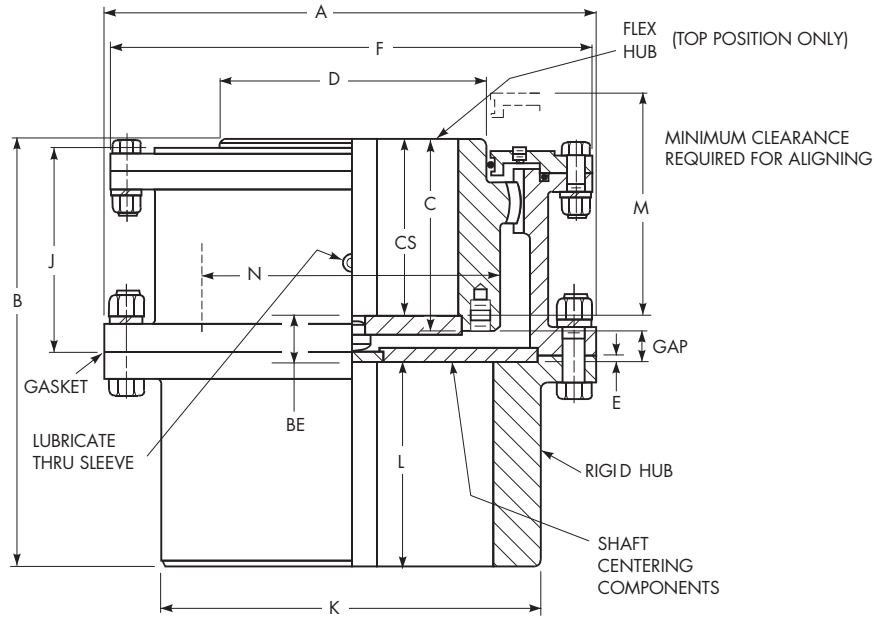

## Dimensions (in)

Size ①	Torque Rating (lb-in – millions) ④		Allow Speed RPM ⑤	Max Bore One Rect Key ②		Min Bore Both Hubs ⑥	Cplg Wt with No Bore (lb)	Lube Wt (lb)	A	B	C	D	E	F	J	K ③	L	M	N	BE	CS	GAP
	1000 Series	2000 Series		Flex Hub	Rigid Hub																	
1080/2080G	1.506	2.070	1,750	10.50	13.25	4.00	1540	11	23.25	20.14	9.32	14.00	0.31	22.50	9.56	17.75	9.80	11.31	14.50	1.52	8.82	1.02
1090/2090G	1.997	2.791	1,550	11.25	15.00	4.50	2170	14	26.00	22.33	10.31	15.50	0.31	25.25	10.44	20.00	10.86	12.38	16.50	1.66	9.81	1.16
1100/2100G	2.747	3.919	1,450	12.75	15.50	5.00	2760	17	28.00	24.62	11.37	17.50	0.38	27.50	11.56	20.88	12.00	13.38	18.50	1.90	10.75	1.28
1110/2110G	3.654	5.393	1,330	14.00	17.25	5.50	3610	20	30.50	26.88	12.49	19.50	0.38	29.50	12.69	23.00	13.12	14.50	20.50	1.90	11.87	1.28
1120/2120G	4.914	6.880	1,200	15.25	19.00	6.00	4580	24	33.00	28.40	13.25	21.50	0.38	32.50	13.44	25.50	13.87	15.25	22.50	1.90	12.63	1.28
1130/2130G	6.363	8.190	1,075	16.25	20.75	6.50	5670	37	35.88	30.00	13.86	23.00	0.38	34.88	14.25	27.88	14.62	16.50	24.00	2.16	13.24	1.54
1140/2140G	8.064	10.080	920	17.75	22.00	7.00	6750	38	38.00	31.75	14.72	25.00	0.38	37.00	14.88	29.50	15.50	17.38	26.00	2.16	14.10	1.54
1150/2150G	9.702	11.970	770	19.00	24.00	7.50	8270	46	40.50	33.75	15.74	27.00	0.38	39.50	16.06	32.00	16.50	18.38	28.00	2.16	15.12	1.54
1160/2160G	11.592	14.490	650	21.00 ②	26.00 ②	10.00	10210	48	43.75	35.75	16.38	29.00	0.50	42.75	16.50	34.88 ②	17.38	19.00	30.00 ②	2.77	15.63	2.02
1180/2180G	14.679	18.900	480	24.25 ②	30.00 ②	11.25	13380	56	48.00	37.00	17.00	33.00	0.50	47.00	17.12	39.12 ②	18.00	19.75	34.00 ②	2.77	16.25	2.02
1200/2200G	18.963	25.200	370	27.00 ②	33.25 ②	12.50	18700	76	53.50	43.25	20.12	36.50	0.50	51.50	20.25	43.12 ②	21.12	24.25	38.00 ②	2.77	19.38	2.02
1220/2220G	24.066	31.500	290	30.00 ②	38.00 ②	13.75	25750	120	59.50	47.12	21.88	40.00	0.62	58.00	22.25	49.00 ②	23.00	26.00	42.00 ②	3.28	20.88	2.28
1240/2240G	30.744	39.690	270	33.75 ②	40.00 ②	15.00	31720	125	64.25	50.62	23.62	44.50	0.62	62.25	23.88	51.76 ②	24.75	27.50	46.00 ②	3.28	22.62	2.28
1260/2260G	39.753	48.510	250	37.00 ②	43.50 ②	16.25	39070	135	68.75	54.12	25.38	48.50	0.62	66.75	25.50	56.00 ②	26.50	29.50	50.00 ②	3.27	24.38	2.27
1280/2280G	51.660	59.850	230	39.00 ②	46.25 ②	17.50	46540	155	73.50	55.62	26.12	52.50	0.62	71.00	26.25	60.26 ②	27.24	30.25	54.00 ②	3.27	25.12	2.27
1300/2300G	59.850	72.450	220	42.00 ②	50.00 ②	18.75	54480	170	77.75	57.12	26.88	56.50	0.62	75.25	27.00	64.50 ②	28.00	30.50	58.00 ②	3.27	25.88	2.27

- ① See page 12 for General Information. Downward thrust capacity of lower supporting button for Sizes 1080 and larger is 87,000 pounds.
- ② Reduced shank diameter hubs are available where required bore permits. See Table 32, page 46 for selection.
- ③ Dimension K may be an "as-cast" surface, depending upon coupling size and bore.
- ④ Peak torque capacity is two times the published rating.
- ⑤ Consult Factory for higher speeds. Balancing may allow up to a 50% increase in speeds shown.
- ⑥ Minimum bore is the smallest bore to which a Rough Stock Bore (RSB) hub can be bored. Depending upon coupling size, RSB hubs may have only a blind centering hole or a through hole that will permit remachining of the hubs to the minimum bores specified.

**NOTE:** Dimensions subject to change. Certified dimensions of ordered material furnished on request.

# TYPE GL20-4 LARGE FLANGED SLEEVE SLIDE DOUBLE ENGAGEMENT

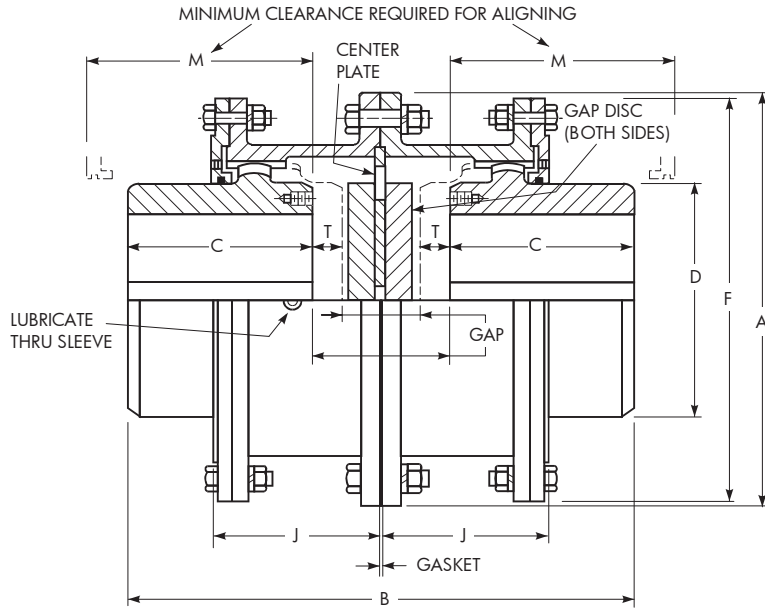

## Dimensions (in)

Size ①	Torque Rating (lb-in – millions) ②		Allow Speed RPM ③	Max Bore One Rect Key ④	Min Bore ⑤	Cplg Wt with No Bore (lb)	Lube Wt (lb)	A	B Max	C	D	F	J	M	T (Max)		GAP	
	1000 Series	2000 Series													Each	Total	Min	Max
1080/2080GL	1.506	2.070	1,160	10.50	4.00	1510	21	23.25	29.14	9.82	14.00	22.50	9.56	11.81	0.55	1.10	8.40	9.50
1090/2090GL	1.997	2.791	1,030	11.25	4.50	2080	27	26.00	31.22	10.88	15.50	25.25	10.44	12.88	0.90	1.80	7.66	9.46
1100/2100GL	2.747	3.919	960	12.75	5.00	2750	33	28.00	35.18	12.00	17.50	27.50	11.56	14.00	0.83	1.66	9.52	11.18
1110/2110GL	3.654	5.393	880	14.00	5.50	3550	39	30.50	39.14	13.12	19.50	29.50	12.69	15.12	0.75	1.50	11.40	12.90
1120/2120GL	4.914	6.880	800	15.25	6.00	4490	46	33.00	41.78	13.88	21.50	32.50	13.44	15.88	0.75	1.50	12.52	14.02

① See page 12 for General Information.

② Peak torque capacity is two times the published rating.

③ Consult Factory for higher speeds. Balancing may allow up to a 50% increase in speeds shown.

④ Maximum bores are reduced for hubs furnished with an interference fit and a setscrew over the keyway. Maximum bores may also be reduced when puller bolt holes are required. Refer to Table 13 and Table 14 on page 38. Bore capacities can be increased beyond values shown if the coupling torque rating is reduced. Refer to the Factory. Recommended key sizes for the listed maximum bores are shown in Table 35, page 48, and Table 23, page 43.

⑤ Minimum bore is the smallest bore to which a Rough Stock Bore (RSB) hub can be bored. Depending upon coupling size, RSB hubs may have only a blind centering hole or a through hole that will permit remachining of the hubs to the minimum bores specified.

**NOTE:** Dimensions subject to change. Certified dimensions of ordered material furnished on request.

# TYPE G70 LARGE DISCONNECT

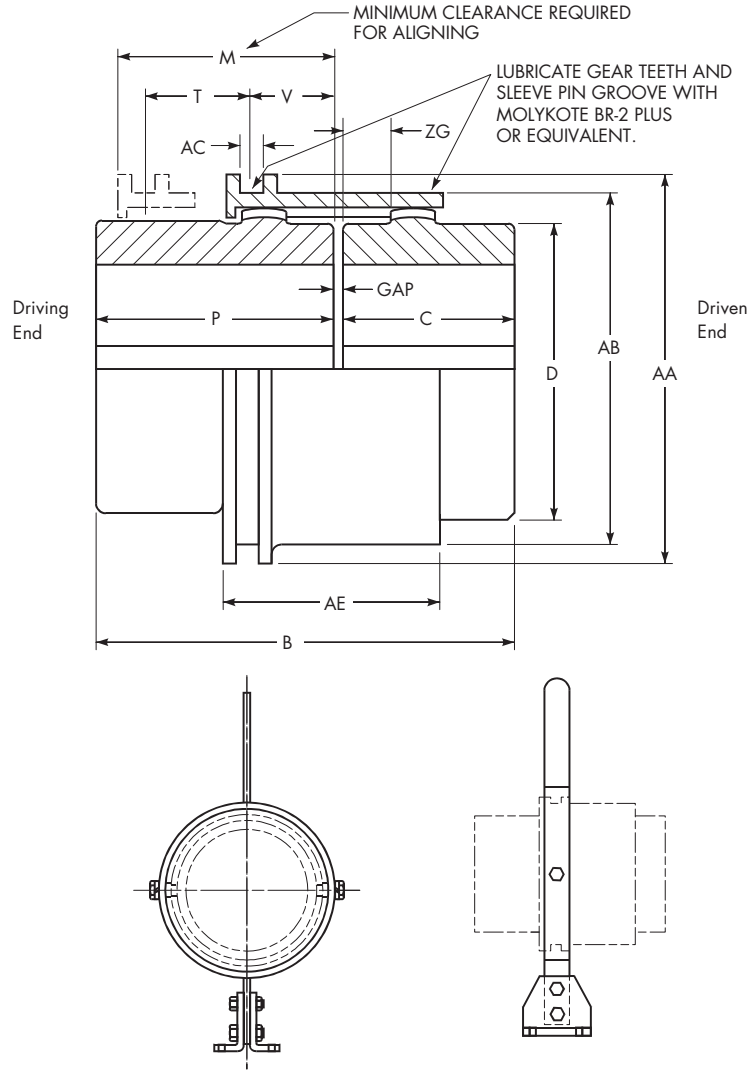

Optional hand-operated shifter mechanism to shift and secure the proper position of the sleeve assembly.

## Dimensions (in)

Size ①	Torque Rating (lb-in – millions) ②	Allow Speed RPM ③	Max Bore One Rect Key ④	Min Bore ⑤	Cplg Wt with No Bore (lb)	B	C	D	M	P	T	V	AA	AB	AC	AE	ZG	GAP
1080G	1.506	110	10.50	4.00	1098	20.00	9.82	14.50	9.00	9.82	4.26	3.48	19.36	18.16	0.76	8.50	1.63	0.375
1090G	1.997	100	11.25	4.50	1538	22.02	10.88	16.50	10.38	10.64	5.14	3.74	21.90	20.30	1.00	9.88	2.08	0.500
1100G	2.747	90	12.75	5.00	2108	24.50	12.00	18.50	11.14	12.00	5.40	4.24	23.90	22.30	1.00	10.64	2.08	0.500
1110G	3.654	80	14.00	5.50	2769	26.74	13.12	20.50	11.66	13.12	5.66	4.50	25.80	24.20	1.00	11.16	2.08	0.500
1120G	4.914	75	15.25	6.00	3436	27.66	13.88	22.50	11.50	13.28	5.88	4.12	28.00	26.40	1.00	11.00	2.06	0.500
1130G	6.363	70	16.25	6.50	3922	27.44	13.34	24.00	11.36	13.34	5.58	4.04	30.64	28.64	1.24	10.86	1.26	0.750
1140G	8.064	65	17.75	7.00	4690	28.32	13.78	26.00	11.36	13.78	5.58	4.04	32.60	30.60	1.24	10.86	1.06	0.750
1150G	9.702	60	19.00	7.50	5782	30.32	14.78	28.00	11.36	14.78	5.58	4.04	34.74	32.74	1.24	10.86	0.84	0.750

① See page 12 for General Information.

② Peak torque capacity is two times the published rating.

③ Consult Factory for higher speeds. Balancing may allow up to a 50% increase in speeds shown.

④ Maximum bores are reduced for hubs furnished with an interference fit and a setscrew over the keyway. Maximum bores may also be reduced when puller bolt holes are required. Refer to Table 13 and Table 14 on page 38. Bore capacities can be increased beyond values shown if the coupling torque rating is reduced. Refer to the Factory. Recommended key sizes for the listed maximum bores are shown in Table 35, page 48, and Table 23, page 43.

⑤ Minimum bore is the smallest bore to which a Rough Stock Bore (RSB) hub can be bored. Depending upon coupling size, RSB hubs may have only a blind centering hole or a through hole that will permit remachining of the hubs to the minimum bores specified.

**NOTE:** Dimensions subject to change. Certified dimensions of ordered material furnished on request.

# TYPE G82 LARGE FLANGED SLEEVE RIGID

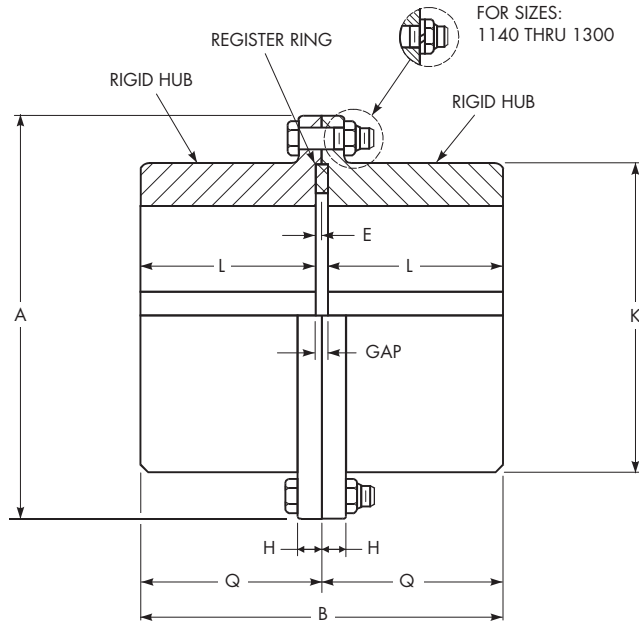

## Dimensions (in)

Size ①	Torque Rating (lb-in – millions) ④	Allow Speed RPM ⑤	Max Bore One Rect Key ⑥	Min Bore ⑦	Cplg Wt with No Bore (lb)	A	B	E	H	K ③	L	Q	GAP
1080G	1.506	1,750	13.25	4.00	1540	23.25	20.24	0.32	1.24	17.75	9.80	10.12	0.64
1090G	1.997	1,550	15.00	4.50	2170	26.00	22.36	0.32	1.50	20.00	10.86	11.18	0.64
1100G	2.747	1,450	15.50	5.00	2660	28.00	24.76	0.38	1.74	20.88	12.00	12.38	0.76
1110G	3.654	1,330	17.25	5.50	3530	30.50	27.00	0.38	2.00	23.00	13.12	13.50	0.76
1120G	4.914	1,200	19.00	6.00	4520	33.00	28.50	0.38	2.12	25.50	13.87	14.25	0.76
1130G	6.363	1,075	20.75	6.50	5640	35.88	30.00	0.38	2.12	27.88	14.62	15.00	0.76
1140G	8.064	920	22.00	7.00	6680	38.00	31.76	0.38	2.12	29.50	15.50	15.88	0.76
1150G	9.702	770	24.00	7.50	8260	40.50	33.76	0.38	2.12	32.00	16.50	16.88	0.76
1160G	11.592	650	26.00 ②	10.00	10320	43.75	35.76	0.50	2.25	34.88 ②	17.38	17.88	1.00
1180G	14.679	480	30.00 ②	11.25	13280	48.00	37.00	0.50	2.25	39.12 ②	18.00	18.50	1.00
1200G	18.963	370	33.25 ②	12.50	18900	53.50	43.24	0.50	2.50	43.12 ②	21.12	21.62	1.00
1220G	24.066	290	38.00 ②	13.75	26220	59.50	47.24	0.62	2.50	49.00 ②	23.00	23.62	1.24
1240G	30.744	270	40.00 ②	15.00	32020	64.25	50.74	0.62	3.00	51.76 ②	24.75	25.38	1.24
1260G	39.753	250	43.50 ②	16.25	39760	68.75	54.24	0.62	3.00	56.00 ②	26.50	27.12	1.24
1280G	51.660	230	46.25 ②	17.50	47340	73.50	55.72	0.62	3.24	60.26 ②	27.24	27.86	1.24
1300G	59.850	220	50.00 ②	18.75	55390	77.75	57.24	0.62	3.24	64.50 ②	28.00	28.62	1.24

① See page 12 for General Information.

② Dimension K may be an “as-cast” surface, depending upon coupling size and bore.

③ For standard shank diameter hubs.

④ Peak torque capacity is two times the published rating.

⑤ Consult Factory for higher speeds. Balancing may allow up to a 50% increase in speeds shown.

⑥ Maximum bores are reduced for hubs furnished with an interference fit and a setscrew over the keyway. Maximum bores may also be reduced when puller bolt holes are required. Refer to Table 13 and Table 14 on page 38. Bore capacities can be increased beyond values shown if the coupling torque rating is reduced. Refer to the Factory. Recommended key sizes for the listed maximum bores are shown in Table 35, page 48, and Table 23, page 43.

⑦ Minimum bore is the smallest bore to which a Rough Stock Bore (RSB) hub can be bored. Depending upon coupling size, RSB hubs may have only a blind centering hole or a through hole that will permit remachining of the hubs to the minimum bores specified.

**NOTE:** Dimensions subject to change. Certified dimensions of ordered material furnished on request.

# TYPE G STANDARD FLANGED SLEEVE MILL MOTOR & TAPER BORES

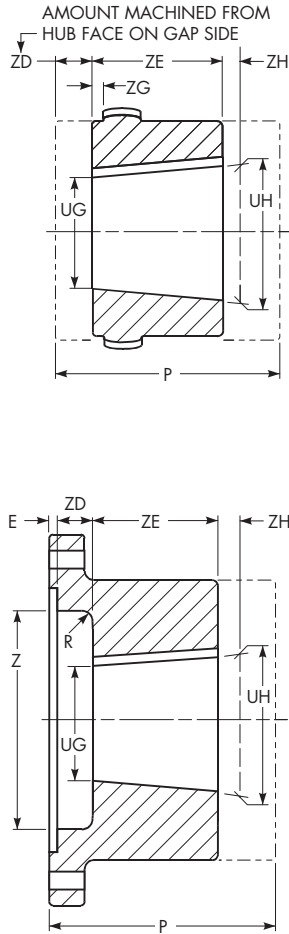

**TABLE 9 – Standard AISE AC & DC Mill Motor Coupling Selections – Dimension (in)**

Motor Frame Size			Coupling Size ①	E	R	UG	UH	Keyway	Z	ZD	ZE	ZG	ZH +.xxx -.000
2 602	802 A, B & C	AC 1, 2 & 4	1015G	0.10									0.06
			1020G	0.10	0.31	1.437	1.750	0.500 x 0.250	3.250	0.94	3.00	0.22	.024
			1025G	0.10									0.49
603 604	803 804	-	1015G	0.10									0.00
			1020G	0.10	0.38	1.635	2.000	0.500 x 0.250	3.375	1.00	3.50	0.16	.029
			1025G	0.10									0.43
606	806	AC 8 & 12	1030G	0.10									0.75
			1035G	0.10	0.38	2.083	2.500	0.500 x 0.250	4.000	1.12	4.00	0.30	.029
			1040G	0.10									1.00
608	808	-	1025G	0.10									0.18
			1030G	0.10	0.50	2.531	3.000	0.750 x 0.250	5.250	1.25	4.50	0.50	.029
			1035G	0.10									0.88
610	810	AC18	1040G	0.16									1.26
			1045G	0.16	0.25	2.781	3.250	0.750 x 0.250	5.625 ②	1.38	4.50	0.38	.034
			1050G	0.16									0.76
612	812	AC 25 & 30	1045G	0.16									1.14
			1050G	0.16	0.50	3.104	3.625	0.750 x 0.250	6.250	1.50	5.00	0.63	.034
			1055G	0.16									1.01
614	814	AC 40 & 50	1045G	0.16									1.27
			1050G	0.20	0.50	3.729	4.250	1.000 x 0.375	6.875	1.62	5.00	0.50	.034
			1055G	0.20									1.15
616	816	-	1045G	0.16			4.559 ③		7.690 ③	4.870 ③	0.38		
			1050G	0.16	0.62	4.052	4.625	1.250 x 0.375	7.875	1.75	5.500	0.76	.034
			1055G	0.16			4.625		7.875		5.500	1.02	
618	818	-	1050G	0.20			4.625		7.875		1.46		
			1055G	0.20	0.62	4.375	5.000	1.250 x 0.500	8.375	1.32	6.00	1.20	.038
			1060G	0.20									1.91
620	820	-	1045G	0.16									1.02
			1050G	0.20	0.75	5.172	5.875	1.500 x 0.750	9.750	1.75	6.75	1.47	.038
			1055G	0.20									2.02
622	822	-	1045G	0.16									0.40
			1050G	0.20	0.75	5.495	6.250	1.500 x 0.750	9.750	2.37	7.25	0.85	.038
			1055G	0.20									1.39
624	824	-	1060G	0.26									1.64
			1070G	0.33	0.75	6.037	7.000	1.500 x 0.750	9.750	2.37	9.25	0.84	.038
													1.64

① See page 12 for General Information. Minimum coupling selections are based on coupling bore capacity.

Check coupling rating for all selections. Refer to pages 13 and 15 for coupling dimensions.

② Spanner wrench required for Size 1025G.

③ For rigid hub only.

**TABLE 10 – Taper and Counter Bore Limitations ④ – Dimension (in)**

Size ①	Flex Hub						Rigid Hub					
	P Max ⑤	UG Min	UH Max	ZD Max	ZE Min	Keyway ⑥	P Max ⑤	UG Min	UH Max	ZD Max	ZE Min	Keyway ⑥
1010G	4.00	0.50	1.88	0.73	1.69	0.500 x 0.250	4.10	0.50	2.38	3.00	1.56	0.500 x 0.250
1015G	4.50	0.75	2.38	1.00	1.94	0.625 x 0.312	4.60	0.75	2.94	3.38	1.82	0.625 x 0.312
1020G	5.12	1.00	2.88	1.16	2.44	0.750 x 0.375	5.22	1.00	3.75	4.00	2.30	0.750 x 0.375
1025G	5.88	1.25	3.62	1.43	3.03	0.875 x 0.438	5.98	1.25	4.38	5.62	2.90	0.875 x 0.438
1030G	6.50	1.50	4.12	1.75	3.59	1.000 x 0.500	6.60	1.50	5.12	6.25	3.46	1.000 x 0.500
1035G	7.25	2.00	4.88	2.13	4.19	1.250 x 0.625	6.72	2.00	5.88	6.88	4.02	1.250 x 0.625
1040G	8.00	2.50	5.75	2.51	4.75	1.500 x 0.750	7.52	2.50	6.75	8.38	4.50	1.500 x 0.750
1045G	9.62	3.00	6.50	2.77	5.31	1.500 x 0.750	9.82	3.00	7.50	9.75	5.10	1.500 x 0.750
1050G	11.62	3.50	7.00	3.22	6.03	1.750 x 0.875	11.82	3.50	8.75	10.75	5.80	1.750 x 0.875
1055G	11.75	4.00	7.75	3.77	6.62	2.000 x 1.000	11.94	4.00	9.50	11.75	6.80	2.000 x 1.000
1060G	12.00	4.50	8.75	4.02	7.41	2.000 x 1.000	12.25	4.50	10.50	13.00	7.34	2.000 x 1.000
1070G	12.20	5.00	10.00	4.73	8.69	2.500 x 1.250	12.32	5.00	12.00	15.00	8.67	2.500 x 1.250

④ This table specifies the taper bore limitations for the usual requirements. For hubs longer than those listed, refer to the Factory.

⑤ Standard Long Hub length; consult the Factory for longer lengths.

⑥ Keyway shown is for maximum bore with square key.

**NOTE:** Dimensions subject to change. Certified dimensions of ordered material furnished on request.

# ENGINEERING DATA — STANDARD FLANGED SLEEVE & CONTINUOUS SLEEVE

**TABLE 10 – Limited End Float & Standard Gap Disc Dimensions (in)**

Size	B	End Float ⑦	Gap Disc ⑧		GAP
			Thickness	Dia	
1080/2080G	20.36	.188	.625	16.38	.719
1090/2090G	22.73	.188	.875	18.50	.969
1100/2100G	24.97	.188	.875	20.50	.969
1110/2110G	27.21	.188	.875	22.38	.969
1120/2120G	28.73	.188	.875	24.50	.969
1130/2130G	30.65	.188	1.312	26.62	1.406
1140/2140G	32.37	.188	1.312	28.62	1.406
1150/2150G	34.41	.188	1.312	30.62	1.406

⑦ If this value exceeds one-half rotor end float or equivalent manufacturer's specifications, refer to the Factory.

⑧ Gap disc material: Neoprene, 70 durometer.

**TABLE 11 – Shaft Diameters & Ratings for NEMA 60 Hertz & 50 Hertz Metric Motors**

**NEMA 60 Hertz Motors (HP)**

Frame Size		T Frames																	
		143	145	182	184	213	215	254	256	284	286	324	326	364	365	404	405	444	445
Shaft	Diameter	0.88	0.88	1.13	1.13	1.38	1.38	1.63	1.63	1.88	1.88	2.13	2.13	2.38	2.38	2.88	2.88	3.38	3.38
3600 RPM	Drip Proof	1-1/2	2-3	5	7-1/2	10	15	20	25	30	40	50	60	75	100	125	150	200	250
	Enclosed	1-1/2	2	3	5	7-1/2	10	15	20	25	30	40	50	60	75	–	100	125	150
1800 RPM	Drip Proof	1	1-1/2-2	3	5	7-1/2	10	15	20	25	30	40	50	60	75	100	125	150	200
	Enclosed	1	1-1/2-2	3	5	7-1/2	10	15	20	25	30	40	50	60	75	–	100	125	150
1200 RPM	Drip Proof & Enclosed	3/4	1	1-1/2	2	3	5	7-1/2	10	15	20	25	30	40	50	60	75	100	125
900 RPM	Drip Proof & Enclosed	1/2	3/4	1	1-1/2	2	3	5	7-1/2	10	15	20	25	30	40	50	60	75	100

**NEMA 60 Hertz Motors (HP)**

Frame Size		TS Frames									
		284	286	324	326	364	365	404	405	444	445
Shaft	Diameter	1.63	1.63	1.88	1.88	1.88	1.88	2.13	2.13	2.38	2.38
3600 RPM	Drip Proof	30	40	50	60	75	100	125	150	200	250
	Enclosed	25	30	40	50	60	75	–	100	125	150
1800 RPM	Drip Proof	25	30	40	50	60	75	100	125	150	200
	Enclosed	25	30	40	50	60	75	–	100	125	150
1200 RPM	Drip Proof & Enclosed	15	20	25	30	40	50	60	75	100	125
900 RPM	Drip Proof & Enclosed	10	15	20	25	30	40	50	60	75	100

**50 Hertz Metric Motors (kW)**

Frame Size	80	90S	90L	100L	112M	132S	132M	160M	160L	180M	180L	200M/L	225S	225M	250S	250M	280S	280M
Shaft Diameter	19	24	24	28	28	38	38	42	42	48	48	55	55	55	60.65	60.65	65, 75	65, 75
													60	60	60	70	70	80
3000 RPM	0.75	1.5	2.2	3.0	4	5.5		11	18.5	22	30	30	45	45	55	55	75	90
	1.10					7.5	15	37				75				90	110	
1500 RPM	0.55	1.1	1.5	2.2	4	5.5	7.5	11	15	18.5	22	30	37	45	55	55	75	90
	0.75			3.0								4				5.5	7.5	11
1000 RPM	0.37	0.75	1.1	1.5	2.2	3	4	7.5	11	15	18.5	18.5	30	30	37	37	45	55
	0.55						5.5					7.5				11	15	18.5
750 RPM	0.18	0.37	0.55	0.75	1.5	2.2	3	4	7.5	11	15	18.5	22	30	30	30	37	45
	0.25			1.1				1.5								2.2	3	5.5

# ENGINEERING DATA — STANDARD FLANGED SLEEVE

**TABLE 12 – Type G Flex/Pilot Hub Maximum Bores (in/mm)**

Size ①	Inches										Millimeters — Fits Per Table 12				
	With One Square Key			With One Rectangular Key						Max Bore ③		Min Bore ④	Max Bore ③		
	Max Bore ③	Y=X		Max Bore ③	Y=X		Max Bore ③	Y=W/2		Int Fit w/ Set Screw Over Keyway	With Puller Holes per Table 17		Std Bore Fits per Table 15	Int Fit w/ Set Screw Over Keyway	With Puller Holes per Table 17
		W	X		W	X		W	X						
1010G	1.875 ②	0.500	0.250	2.000	0.500	0.187	2.125	0.500	0.125	1.750	1.500	13	50	45	38
1015G	2.375 ②	0.625	0.312	2.500	0.625	0.218	2.750	0.625	0.125	2.250	2.125	20	65	60	54
1020G	2.875 ②	0.750	0.375	3.125	0.750	0.250	3.250	0.750	0.125	2.750	2.875	26	78	75	72
1025G	3.625 ②	0.875	0.437	3.875	1.000	0.375	4.000	1.000	0.250	3.250	3.625	32	98	88	92
1030G	4.125 ②	1.000	0.500	4.375	1.000	0.375	4.750	1.250	0.250	3.750	4.125	39	111	101	104
1035G	4.875 ②	1.250	0.625	5.250	1.250	0.437	5.750	1.500	0.250	4.500	4.875	51	134	121	124
1040G	5.750 ②	1.500	0.750	6.250	1.500	0.500	6.500	1.500	0.250	5.500	5.750	64	160	150	146
1045G	6.500	1.500	0.750	6.750 ②	1.750	0.750	—	—	—	5.750	6.750	77	183	160	171
1050G	7.000	1.750	0.875	7.375 ②	1.750	0.750	—	—	—	6.500	7.375	89	200	177	187
1055G	7.750	2.000	1.000	8.250 ②	2.000	0.750	—	—	—	7.500	8.250	102	220	200	209
1060G	8.750	2.000	1.000	9.125 ②	2.500	0.875	—	—	—	8.000	9.125	115	244	212	232
1070G	10.000	2.500	1.250	10.875 ②	2.500	0.875	—	—	—	9.000	10.875	127	289	235	276

**TABLE 13 – Type G Rigid Hub & Maximum Bores (in/mm)**

Size ①	Inches										Millimeters — Fits Per Table 12				
	With One Square Key			With One Rectangular Key						Max Bore ③		Min Bore ④	Max Bore ③		
	Max Bore ③	Y=X		Max Bore ③	Y=X		Max Bore ③	Y=W/2		Int Fit w/ Set Screw Over Keyway	With Puller Holes per Table 17		Std Bore Fits per Table 15	Int Fit w/ Set Screw Over Keyway	With Puller Holes per Table 17
		W	X		W	X		W	X						
1010G	2.375 ②	0.625	0.312	2.500	0.625	0.218	2.750	0.625	0.125	2.250	2.000	13	65	60	51
1015G	2.937 ②	0.750	0.375	3.250	0.750	0.250	3.375	0.875	0.187	2.750	2.750	20	80	75	70
1020G	3.625 ②	0.875	0.437	3.875	1.000	0.375	4.000	1.000	0.250	3.250	3.625	26	98	88	92
1025G	4.375 ②	1.000	0.500	4.625	1.250	0.437	4.875	1.250	0.250	3.875	4.375	32	118	107	111
1030G	5.125 ②	1.250	0.625	5.500	1.250	0.437	5.875	1.500	0.250	4.500	5.125	39	140	121	130
1035G	5.875 ②	1.500	0.750	6.500	1.500	0.500	—	—	—	5.500	5.875	51	163	150	150
1040G	6.750	1.750	0.875	7.250 ②	1.750	0.750	—	—	—	6.000	7.250	64	196	167	185
1045G	7.625	1.750	0.875	8.125 ②	2.000	0.750	—	—	—	7.000	8.125	77	216	190	205
1050G	8.750	2.000	1.000	9.000 ②	2.000	0.750	—	—	—	8.250	9.000	89	235	220	228
1055G	9.750	2.000	1.000	10.000 ②	2.500	0.875	—	—	—	8.750	10.000	102	266	230	250
1060G	10.500	2.500	1.250	11.000 ②	2.500	0.875	—	—	—	9.750	11.000	115	290	260	280
1070G	12.000	3.000	1.500	13.000 ②	3.000	1.000	—	—	—	11.000	13.000	127	340	290	330

① See page 12 for General Information.

② Maximum bores for standard keys recommended in Table 33.

③ Maximum bores are reduced for hubs furnished with an interference fit and a setscrew over the keyway. Maximum bores may also be reduced when puller bolt holes are required. Refer to Table 13 and Table 14 on page 38. Bore capacities can be increased beyond values shown if the coupling torque rating is reduced. Refer to the Factory. Recommended key sizes for the listed maximum bores are shown in Table 35, page 48, and Table 23, page 43.

④ Minimum bore is the smallest bore to which a Rough Stock Bore (RSB) hub can be bored. Depending upon coupling size, RSB hubs may have only a blind centering hole or a through hole that will permit remachining of the hubs to the minimum bores specified.

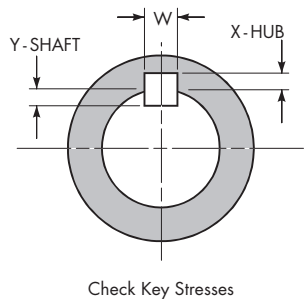

**TABLE 14 – Recommended Bore Tolerances Falk™ Lifelign™ Steel Coupling Hubs (mm)**

Shaft Diameter (ISO/R775-1969)		Bore Diameter Tolerance		
Nominal	Tolerance	Clearance	Transitional	Interference
6 to 30	j6/k6 ⑤	F7	H7	M6
Over 30 to 50	k6	F7	H7	K6
Over 50 to 80	m6	F7	H7	K7
Over 80 to 100	m6	F7	H7	M7
Over 100 to 200	m6	F7	H7	P7
Over 200 to 355	m6	F7	H7	R7
Over 355 to 500	m6	F7	H7	R8

⑤ Per DIN 748 — Differs with ISO/R775.

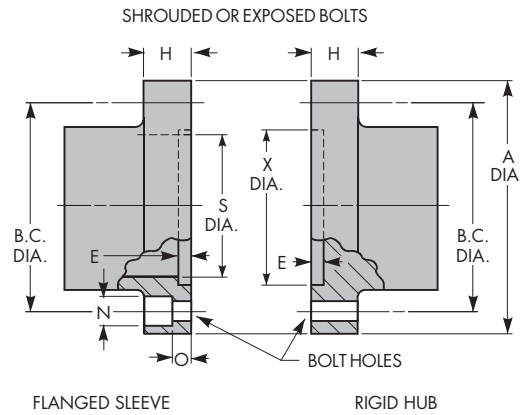
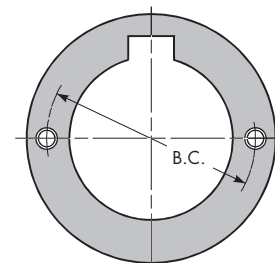

TABLE 15 – Flanged Sleeve and Rigid Hub Details

Size ①	Shrouded or Exposed Bolts					Shrouded				Exposed	
	A + .000 - .004	E ± .010	H	S ± .010	X ± .010	B.C.	Bolt No.-Dia	N	O	B.C.	Bolt No.-Dia
1010G	4.562	0.100	0.55	3.060	3.180	3.750	6-0.250	0.46	0.250	3.750	6-0.250
1015G	6.000	0.100	0.75	3.810	3.920	4.812	8-0.375	0.58	0.250	4.812	8-0.375
1020G	7.000	0.100	0.75	4.640	4.800	5.812	10-0.375	0.58	0.250	5.875	6-0.500
1025G	8.375	0.100	0.86	5.700	5.860	7.000	10-0.500	0.78	0.320	7.125	6-0.625
1030G	9.438	0.100	0.86	6.660	6.820	8.000	12-0.500	0.78	0.320	8.125	8-0.625
1035G	11.000	0.100	1.12	7.690	7.860	9.281	12-0.625	0.97	0.400	9.500	8-0.750
1040G	12.500	0.160	1.12	9.060	9.250	10.625	14-0.625	0.97	0.400	11.000	8-0.750
1045G	13.625	0.160	1.12	10.060	10.250	11.750	14-0.625	0.97	0.400	12.000	10-0.750
1050G	15.313	0.200	1.50	11.060	11.420	13.188	14-0.750	1.16	0.560	13.500	8-0.875
1055G	16.750	0.200	1.50	12.090	12.420	14.438	16-0.750	1.16	0.560	14.500	14-0.875
1060G	18.000	0.260	1.00	13.280	13.920	—	—	—	—	15.750	14-0.875
1070G	20.750	0.330	1.12	15.300	15.940	—	—	—	—	18.250	16-1.000

TABLE 16 – Puller Bolt Holes (Conforms to API 610 Specifications)

Size ①	B.C.		Tap Size UNC
	Flex Hub/Pilot Hub	Rigid Hub	
1010G ②	2.060	2.625	0.375-16 x 0.50
1015G ②	2.750	3.375	0.375-16 x 0.50
1020G	3.500	4.250	0.375-16 x 0.50
1025G	4.440	5.240	0.375-16 x 0.50
1030G	5.060	6.160	0.375-16 x 0.50
1035G	6.000	7.180	0.500-13 x 0.62
1040G	7.125	8.260	0.625-11 x 0.75
1045G	7.875	9.180	0.625-11 x 0.75
1050G	8.500	10.200	0.750-10 x 0.88
1055G	9.375	11.200	0.750-10 x 0.88
1060G	10.375	12.460	0.750-10 x 0.88
1070G	12.250	14.500	1.000-8 x 1.18



Puller bolt holes are available for an extra charge.

① See page 12 for General Information.  
 ② See Table 13 and Table 14 for maximum bore limitations.

NOTE: Dimensions subject to change. Certified dimensions of ordered material furnished on request.

# ENGINEERING DATA — STANDARD FLANGED SLEEVE (Cont.)

**TABLE 17 – Torsional Stiffness—lb-in/Radian (10<sup>6</sup>) with No Bores**

Size ①	Exposed Bolt Types				Shrouded Bolt Types			
	Half Couplings		Complete Couplings		Half Couplings		Complete Couplings	
	Flex Half	Rigid Half	G20 GP20	G52 GP52	Flex Hub	Rigid Hub	G10	G51
1010G	42	91	21	28	28	84	14	21
1015G	107	213	53	71	79	188	39	55
1020G	162	349	81	110	128	317	64	91
1025G	246	611	123	177	197	557	99	146
1030G	355	912	177	255	293	848	146	218
1035G	469	1501	234	357	496	1371	248	364
1040G	963	2376	481	685	698	2138	349	526
1045G	1223	3144	611	880	1017	2942	508	756
1050G	1966	4226	983	1342	1573	4052	786	1133
1055G	2167	5375	1083	1554	1954	4994	977	1404
1060G	2588	6584	1294	1857	—	—	—	—
1070G	4276	10202	2138	3013	—	—	—	—

**TABLE 18 – WR<sup>2</sup> (lb-in<sup>2</sup>) Values with No Bores**

Size ①	Type G and GP											Type GL		Type GV			
	G10	G20 GP20	G32 ②		Spacer WR <sup>2</sup> per inch ③	G51	G52 GP52	G70	G72	G81	G82 GP82 GV82	GL20	GL52	GV10	GV20	GV51	GV52
			Min BE	Cplg. WR <sup>2</sup>													
1010G	16	19	3.25	35	1.51	17	20	11	21	17	20	20	20	16	19	17	20
1015G	55	70	3.25	125	1.81	56	71	29	77	57	73	72	72	54	69	57	72
1020G	123	150	3.25	245	4.10	130	155	80	170	135	160	155	155	125	145	130	160
1025G	302	385	3.75	610	7.78	320	400	210	425	340	420	395	405	305	385	325	405
1030G	580	705	3.75	1,085	11.67	620	745	450	800	660	785	740	760	580	705	625	750
1035G	1,320	1,625	4.75	2,495	26.50	1,390	1,695	940	1,780	1,440	1,765	1,685	1,720	1,310	1,615	1,385	1,705
1040G	2,595	3,105	4.75	4,520	49.10	2,735	3,250	1,970	3,355	2,850	3,400	3,260	3,300	2,580	3,090	2,750	3,285
1045G	4,235	5,035	4.75	7,060	88.30	4,475	5,195	3,440	5,170	4,680	5,360	5,270	5,270	4,195	4,995	4,495	5,235
1050G	7,530	8,990	5.75	13,220	120.00	8,040	9,520	5,610	9,510	8,545	10,040	9,425	9,670	7,550	9,010	8,155	9,635
1055G	12,470	13,785	5.75	19,755	159.00	13,555	15,000	8,190	14,300	14,630	16,190	14,465	15,220	12,485	13,795	13,710	15,170
1060G	—	18,210	5.75	24,245	226.00	—	19,795	13,520	20,810	—	21,375	19,430	20,205	—	18,340	—	20,165
1070G	—	38,760	5.75	50,620	332.00	—	42,040	28,320	40,350	—	45,295	41,150	42,775	—	38,880	—	42,780

- ① See page 12 for General Information.
- ② To determine total WR<sup>2</sup> of spacer couplings with a BE (distance between shaft ends) greater than minimum:
  1. Subtract minimum BE from required BE.
  2. Multiply the result of Step 1 by the appropriate spacer WR<sup>2</sup> and add to coupling WR<sup>2</sup> at minimum BE.
- ③ Values apply to the tube portion only. Flange WR<sup>2</sup> is included in the spacer WR<sup>2</sup> for minimum BE.

**TABLE 19 – Standard Filleted Keyways & Chamfered Keys (in)**

Nominal		Key		Hub Keyway			
Over	Thru	Size (Nominal)	45° Chamfer Suggested	Width		Depth ④ + .010 to + .020	Fillet Radii
0.438	0.562	0.125 x 0.125	0.031	0.125		0.062	0.016
0.562	0.875	0.187 x 0.187	0.031	0.187		0.093	0.016
0.875	1.250	0.250 x 0.250	0.031	0.250		0.125	0.016
1.250	1.375	0.312 x 0.312	0.047	0.312		0.156	0.031
1.375	1.750	0.375 x 0.375	0.047	0.3750		0.187	0.031
1.750	2.250	0.500 x 0.500	0.047	0.5000		0.250	0.031
2.250	2.750	0.625 x 0.625	0.078	0.625		0.312	0.062
2.750	3.250	0.750 x 0.750	0.078	0.750		0.375	0.062
3.250	3.750	0.875 x 0.875	0.078	0.875		0.437	0.062
3.750	4.500	1.000 x 1.000	0.078	1.000		0.500	0.062
4.500	5.500	1.250 x 1.250	0.156	1.2500		0.625	0.125
5.500	6.500	1.500 x 1.500	0.156	1.5000		0.750	0.125
6.500	7.500	1.750 x 1.500	0.156	1.750		0.750	0.125
7.500	9.000	2.000 x 1.500	0.156	2.000		0.750	0.125
9.000	11.000	2.500 x 1.750	0.156	2.500		0.875	0.125
11.000	13.000	3.000 x 2.000	0.219	3.000		1.000	0.188

④ Shallow keyway depths must be equal or exceed 2/3 of the full keyway depth of the square keys shown above.

**NOTE:** Dimensions subject to change. Certified dimensions of ordered material furnished on request.

**Variable Gap** — Normally it is not necessary to overhang gear coupling hubs since the hubs can readily be reversed to produce different gap dimensions as illustrated in **Figures 1, 2 and 4** below. Also, long hubs from **Table 10, page 37** can be cut off to suit required gap as illustrated in **Figures 3 and 5** below.

However when the distance between shafts is greater than the allowable coupling gap, overhang one or both hubs. It must be remembered that this practice reduces shaft-hub engagement. If the overhang with a standard hub results in less than 0.75 times the shaft diameter engagement, a coupling with long hubs is recommended. Use the standard interference fit and check key strength.

**CAUTION:** The effect of open keyways on coupling balance should always be considered.

If axial shaft movement is required, use the Type GL slide coupling.

**Double Engagement Couplings**

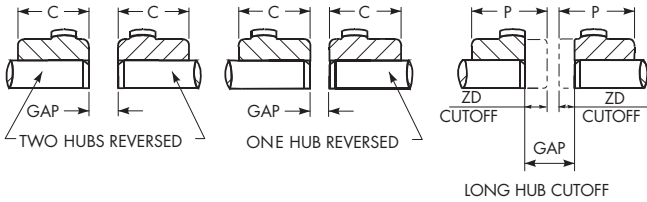

Figure 1

Figure 2

Figure 3

**Single Engagement Couplings**

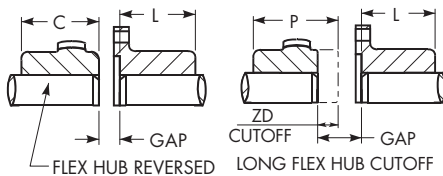

Figure 4

Figure 5

**Misalignment Capacity** — Shaft misalignment can be due to the combined effects of both parallel and angular shaft displacement. Falk™ 1000 Series gear couplings are designed to accommodate a static misalignment of 1-1/2° per gear mesh. The recommended installation misalignment is limited to 1/8° per gear mesh. Axial movement of connected shafts is also accommodated.

It is important that flexible couplings are properly aligned so that the maximum benefits of the equipment can be obtained. These benefits include the following:

1. Longer coupling life with minimum maintenance.
2. Longer life of the connected equipment as a result of reduced bending moments and radial forces which are related to the amount of misalignment.
3. Permit drive systems to have reserve misalignment capacity to accommodate unavoidable alignment changes caused by bearing wear foundation settling, thermal expansion, etc.

Dimension Y must be equal to or greater than Dimension X times 0.75. If not, use long hubs.

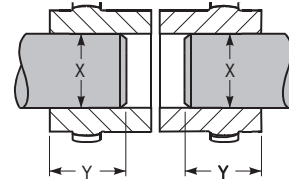

**Double Engagement**

**Single Engagement**

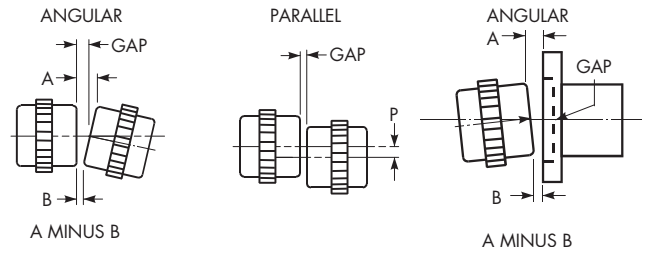

TABLE 20 – Type G Only Variable Gap

Size ①	C Std	L Std	P Max	ZG Max ②	Coupling Gap						
					Double Engagement			Single Engagement			
					Std	Fig 1	Fig 2	Fig 3	Std	Fig 4	Fig 5
1010G	1.69	1.56	4.00	0.728	0.125	0.409	0.267	1.581	0.156	0.298	0.884
1015G	1.94	1.82	4.50	1.000	0.125	1.125	0.625	2.125	0.156	0.656	1.156
1020G	2.44	2.30	5.12	1.160	0.125	1.045	0.585	2.445	0.156	0.616	1.316
1025G	3.03	2.90	5.88	1.430	0.188	1.328	0.758	3.048	0.188	0.758	1.618
1030G	3.59	3.46	6.50	1.750	0.188	1.768	0.978	3.688	0.188	0.978	1.938
1035G	4.19	4.02	7.25	2.130	0.250	2.390	1.320	4.510	0.218	1.288	2.348
1040G	4.75	4.54	8.00	2.510	0.250	3.110	1.680	5.270	0.281	1.711	2.791
1045G	5.31	5.14	9.62	2.770	0.312	3.372	1.842	5.852	0.312	1.842	3.082
1050G	6.03	5.80	11.62	3.220	0.312	4.012	2.162	6.752	0.344	2.194	3.564
1055G	6.62	6.80	11.75	3.770	0.312	5.272	2.792	7.852	0.344	2.824	4.114
1060G	7.41	7.34	12.00	4.020	0.312	5.012	2.662	8.352	0.406	2.756	4.426
1070G	8.69	8.67	12.20	4.730	0.375	5.915	3.145	9.835	0.500	3.270	5.230

① See page 12 for General Information.

② Standard gap must be increased by the amount cut off the hub, or hubs, to maintain the correct flex hub tooth position.

TABLE 21 – Misalignment Capacity (in) ③

Size ①	Double Engagement				Single Engagement Angular Maximum ④	
	Recommended Installation Maximum		Maximum Operating ③		Recommended Installation A Minus B	Maximum Operating A Minus B ③
	Parallel Offset P	Angular A Minus B	Parallel Offset P	Angular A Minus B		
1010G	0.002	0.006	0.026	0.071	0.006	0.035
1015G	0.003	0.007	0.034	0.089	0.007	0.045
1020G	0.003	0.009	0.040	0.108	0.009	0.054
1025G	0.004	0.011	0.050	0.135	0.011	0.067
1030G	0.005	0.013	0.060	0.157	0.013	0.079
1035G	0.006	0.015	0.072	0.183	0.015	0.092
1040G	0.007	0.018	0.084	0.216	0.018	0.108
1045G	0.008	0.020	0.094	0.242	0.020	0.121
1050G	0.009	0.022	0.107	0.262	0.022	0.131
1055G	0.011	0.024	0.123	0.288	0.024	0.144
1060G	0.011	0.026	0.132	0.314	0.026	0.157
1070G	0.013	0.031	0.155	0.367	0.031	0.183

③ These maximum operating alignment limits are each based on 3/4° per flex half coupling. Combined values of parallel and angular misalignment should not exceed 3/4°. Type GL slide couplings are limited to 1/4° per flex half.

④ Do not use single engagement couplings to compensate for parallel offset misalignment.

# ENGINEERING DATA — LARGE FLANGED SLEEVE

**TABLE 22 – Recommended Commercial Keys for Bores with One & Two Keys (in) (Per ANSI B17.1 Standard)**

Shaft Diameter		One Key	Shaft Diameter		Two Keys
Over	Thru		Over	Thru	
3.750	4.500	1.000 x 1.000	9.000	10.500	1.500 x 1.000
4.500	5.500	1.250 x 1.250	10.500	12.000	1.750 x 1.500
5.500	6.500	1.500 x 1.500	12.000	13.500	2.000 x 1.500
6.500	7.500	1.750 x 1.500	13.500	16.000	2.500 x 1.750
7.500	9.000	2.000 x 1.500	16.000	19.500	3.000 x 2.000
9.000	11.000	2.500 x 1.750	19.500	23.000	3.500 x 2.500
11.000	13.000	3.000 x 2.000	23.000	28.000	4.000 x 3.000
13.000	15.000	3.500 x 2.500	28.000	34.000	5.000 x 3.500
15.000	18.000	4.000 x 3.000	34.000	41.000	6.000 x 4.000
18.000	22.000	5.000 x 3.500	41.000	49.000	7.000 x 5.000
22.000	26.000	6.000 x 4.000	49.000	55.000	8.000 x 5.500
26.000	30.000	7.000 x 5.000			
30.000	34.000	8.000 x 5.500			
34.000	38.000	9.000 x 6.000			
38.000	42.000	10.000 x 7.000			
42.000	46.000	11.000 x 7.500			
46.000	50.000	12.000 x 8.000			
50.000	54.000	13.000 x 9.000			

# ENGINEERING DATA — LARGE FLANGED SLEEVE (Cont.)

**TABLE 23 – Flange Details**

Size	A	B	C	E	DD	F	G	H	J-Bolts No. Dia x Length (Per Flange)	K-Bolts No. Dia x Length	T
1080/2080G	23.25	20.750	17.375	0.31	0.25	22.50	20.750	1.25	16- 0.875 x 3.25	16- 1.125 x 4.125	17.373
1090/2090G	26.00	23.250	19.500	0.31	0.25	25.25	23.250	1.50	18- 1.000 x 3.50	18- 1.250 x 4.75	19.498
1100/2100G	28.00	25.250	21.500	0.38	0.31	27.50	25.250	1.75	18- 1.000 x 3.50	18- 1.250 x 5.25	21.498
1110/2110G	30.50	27.500	23.500	0.38	0.31	29.50	27.500	2.00	18- 1.000 x 3.50	18- 1.500 x 6.00	23.498
1120/2120G	33.00	30.000	25.750	0.38	0.31	32.50	30.000	2.12	18- 1.125 x 3.50	18- 1.500 x 6.25	25.748
1130/2130G	35.88	32.375	27.875	0.38	0.31	34.88	32.375	2.12	18- 1.250 x 4.50	18- 1.500 x 6.25	27.873
1140/2140G	38.00	34.500	29.875	0.38	0.31	37.00	34.500	2.12	18- 1.250 x 4.50	18- 1.750 x 6.50	29.873
1150/2150G	40.50	36.750	32.125	0.38	0.31	39.50	36.750	2.12	20- 1.250 x 4.50	20- 1.750 x 6.50	32.123
1160/2160G	43.75	39.750	34.000	0.50	0.38	42.75	39.750	2.25	20- 1.250 x 4.50	20- 2.000 x 7.00	33.996
1180/2180G	48.00	44.000	38.750	0.50	0.38	47.00	44.000	2.25	22- 1.250 x 4.50	22- 2.000 x 7.00	38.746
1200/2200G	53.50	48.500	42.750	0.50	0.38	51.50	48.500	2.50	22- 1.500 x 5.00	22- 2.250 x 7.75	42.746
1220/2220G	59.50	54.500	47.750	0.62	0.50	58.00	54.500	2.50	24- 1.500 x 5.00	24- 2.250 x 7.75	47.746
1240/2240G	64.25	58.250	50.750	0.62	0.50	62.25	58.250	3.00	22- 1.500 x 5.00	22- 2.250 x 9.75	50.746
1260/2260G	68.75	62.750	54.750	0.62	0.50	66.75	62.750	3.00	24- 1.500 x 5.00	24- 2.750 x 9.75	54.746
1280/2280G	73.50	67.000	58.750	0.62	0.50	71.00	67.000	3.25	22- 1.500 x 5.00	22- 3.000 x 10.50	58.746
1300/2300G	77.75	71.250	62.750	0.62	0.50	75.25	71.250	3.25	24- 1.500 x 5.00	24- 3.000 x 10.50	62.746

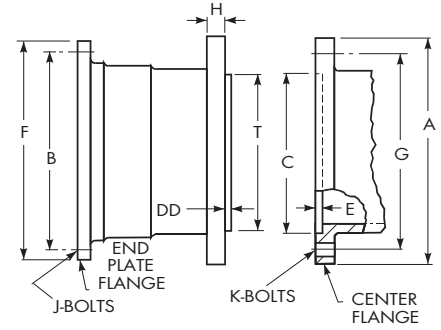

**TABLE 24 – Sleeve Jack Screw Holes**

Size	B.C.	Tap Size
1080/2080G	20.750	0.875-9 UNC
1090/2090G	23.250	1.000-8 UNC
1100/2100G	25.250	1.000-8 UNC
1110/2110G	27.500	1.000-8 UNC
1120/2120G	30.000	1.125-7 UNC
1130/2130G	32.375	1.250-7 UNC
1140/2140G	34.500	1.250-7 UNC
1150/2150G	36.750	1.250-7 UNC
1160/2160G	39.750	1.250-7 UNC
1180/2180G	44.000	1.250-7 UNC
1200/2200G	48.500	1.500-6 UNC
1220/2220G	54.500	1.500-6 UNC
1240/2240G	58.250	1.500-6 UNC
1260/2260G	62.750	1.500-6 UNC
1280/2280G	67.000	1.500-6 UNC
1300/2300G	71.250	1.500-6 UNC

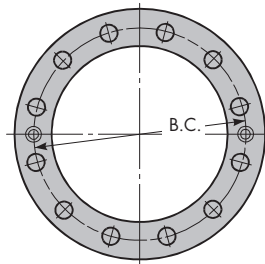

**TABLE 25 – Flex Hub Puller Bolt Holes for Standard Shank Diameter Hubs**

Size ①	B.C.	Tap Size – UNC
1080/2080G	12.500	1.000-8 x 1.18
1090/2090G	14.000	1.250-7 x 1.50
1100/2100G	15.500	1.500-6 x 1.75
1110/2110G	17.500	1.500-6 x 1.75
1120/2120G	19.500	1.500-6 x 1.75
1130/2130G	21.000	1.500-6 x 1.75
1140/2140G	23.000	1.500-6 x 1.75
1150/2150G	25.000	1.500-6 x 1.75
1160/2160G	27.000	1.500-6 x 1.75
1180/2180G	30.500	1.500-6 x 1.75
1200/2200G	34.000	2.000-4.5 x 2.38
1220/2220G	37.500	2.000-4.5 x 2.38
1240/2240G	41.000	2.000-4.5 x 2.38
1260/2260G	45.000	2.000-4.5 x 2.38
1280/2280G	49.000	2.000-4.5 x 2.38
1300/2300G	53.000	2.000-4.5 x 2.38

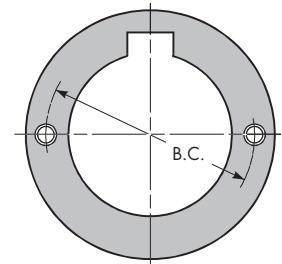

① Refer to **Table 29** for flex hub puller data on reduced shank diameter hubs, Sizes 1160/2160 thru 1300/2300.

**TABLE 26 – Torsional Stiffness – lb-in/Radian (10<sup>6</sup>)**

Size	Half Couplings				Complete Coupling			
	Flex Half	Right Half			Type G20	Type G52		
		Large Shank	Medium Shank	Small Shank		Large Shank	Medium Shank	Small Shank
1080/2080G	4520	12500	–	–	2260	3320	–	–
1090/2090G	6160	18200	–	–	3080	4600	–	–
1100/2100G	7800	19900	–	–	3900	5600	–	–
1110/2110G	9460	26800	–	–	4730	7000	–	–
1120/2120G	12600	38100	–	–	6300	9470	–	–
1130/2130G	15880	51200	–	–	7940	12100	–	–
1140/2140G	18760	60500	–	–	9380	14300	–	–
1150/2150G	22200	77900	–	–	11100	17300	–	–
1160/2160G	30600	106900	65600	26500	15300	23800	20900	14200
1180/2180G	46600	162100	96800	41600	23300	36300	31500	22000
1200/2200G	53000	203600	121300	53300	26500	42000	36800	26600
1220/2220G	95800	308500	158200	72100	47900	73100	59700	41100
1240/2240G	93000	361000	204500	92900	46500	73900	63900	46500
1260/2260G	116800	459000	256600	120200	58400	93100	80300	59300
1280/2280G	153800	599500	331200	159800	76900	122400	105000	78400
1300/2300G	196000	762500	417200	205900	98000	155900	133400	100400

**TABLE 27 – WR<sup>2</sup> Values (lb-in<sup>2</sup>)**

WR<sup>2</sup> values are based on hubs with no bore.

Size	Type G20 Double Engagement	Type G52 Single Engagement
1080/2080G	75,835	72,330
1090/2090G	136,510	129,990
1100/2100G	210,965	189,795
1110/2110G	318,700	295,605
1120/2120G	470,600	445,750
1130/2130G	677,715	644,475
1140/2140G	920,940	874,830
1150/2150G	1,245,820	1,199,785
1160/2160G	1,798,710	1,755,170
1180/2180G	2,903,395	2,832,400
1200/2200G	4,971,175	4,869,620
1220/2220G	8,459,975	8,246,620
1240/2240G	12,184,330	11,935,924
1260/2260G	16,701,335	16,689,170
1280/2280G	22,679,330	22,877,185
1300/2300G	29,876,435	30,100,765

# ENGINEERING DATA — LARGE FLANGED SLEEVE (Cont.)

## Data for couplings with reduced shank diameter hubs:

Depending upon bore, a reduced shank diameter hub (Dimension “N” or “K”) is available for each coupling, sizes 1160/2160 thru 1300/2300. This provides reduced weight and WR<sup>2</sup>.

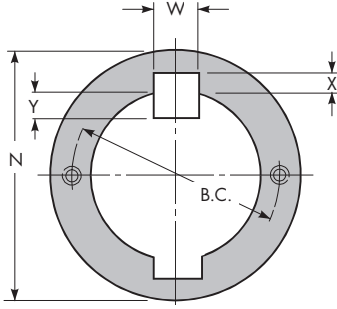

**TABLE 28 –Bore Ranges for Reduced Shank Diameter Hubs (in)**

Size ①	G20							G52									
	Flex Hub			Min Bore	N ②	Weight (lb) ③		Coupling WR <sup>2</sup> (lb-in <sup>2</sup> )	Rigid Hub			K ②	Weight – lbs ③			Coupling WR <sup>2</sup> (lb-in <sup>2</sup> )	
	Max Bore – 2 Rectangular Keys ④					Sleeves, End Rings and Fasteners	Flex Hub with No Bore (Each)		Max Bore – 2 Rectangular Keys ④				Min Bore	Sleeves, End Rings and Fasteners	Flex Hub with No Bore (Each)		Rigid Hub with No Bore (Each)
	Bore	Keyway Y = X							Bore	Keyway Y = X							
W		X	W	X													
1160/2160G	19.25	3.000	1.000	13.00	25.50	3060	1,607,330	23.75	4.000	1.500	14.75	31.00	3060	4190	1,428,355		
	14.25	2.500	0.875	10.00	20.75	2630	1,492,100	17.00	3.000	1.000	10.00	23.50	1650	2630	3050	1,155,020	
1180/2180G	22.25	3.500	1.250	15.00	29.50	4140	2,621,895	26.75	4.000	1.500	16.50	34.50	1950	4140	5320	2,294,025	
	17.00	3.000	1.000	11.25	24.00	3530	2,397,515	19.50	3.000	1.000	11.25	26.50	3530	3940	1,856,755		
1200/2200G	26.00	4.000	1.500	17.00	33.50	6060	4,493,550	29.75	5.000	1.750	18.50	38.00	2610	6060	7570	3,936,305	
	19.75	3.500	1.250	12.50	27.25	5050	3,995,335	22.00	3.500	1.250	12.50	29.50	5050	5620	3,149,480		
1220/2220G	28.75	5.000	1.750	19.25	37.50	8170	7,774,455	33.00	5.000	1.750	20.25	41.50	3800	8170	9850	6,526,670	
	22.75	3.500	1.250	13.75	30.75	6820	6,948,365	24.00	4.000	1.500	13.75	32.50	6820	7410	5,280,030		
1240/2240G	32.50	5.000	1.750	21.25	41.50	10640	11,114,330	35.25	6.000	2.000	22.25	45.00	4360	10640	12550	9,596,235	
	25.00	4.000	1.500	15.00	34.00	8770	9,731,830	26.75	4.000	1.500	15.00	35.50	8770	9400	7,633,675		
1260/2260G	35.25	6.000	2.000	23.25	45.50	13540	15,220,935	38.75	6.000	2.000	24.00	48.50	4770	13540	15460	13,293,705	
	28.00	4.000	1.500	16.25	37.25	11040	15,680,760	28.75	5.000	1.750	16.25	38.50	11040	11680	10,383,120		
1280/2280G	39.00	6.000	2.000	25.50	49.50	16340	20,783,330	41.00	6.000	2.000	26.00	52.00	5550	16340	18340	18,070,985	
	30.00	5.000	1.750	17.50	40.75	13350	17,591,530	31.00	5.000	1.750	17.50	41.50	13350	14070	14,156,425		
1300/2300G	41.25	7.000	2.500	27.50	53.50	19500	27,459,315	43.00	7.000	2.500	27.75	55.50	6210	19500	21320	23,791,805	
	33.00	5.000	1.750	18.75	44.00	15870	23,041,885	33.75	5.000	1.750	18.75	44.50	15870	16460	18,573,830		

① See page 12 for General Information.

② Hubs with the least possible “K” or “N” dimension for the required bore are normally furnished.

③ Total weight of coupling varies with “K” or “N” dimension of rigid and flex hub selection. Add weight of selected hubs to “Sleeve, End Ring and Fasteners” weight.

④ Maximum bores are reduced for hubs furnished with an interference fit and a setscrew over the keyway. Maximum bores may also be reduced when puller bolt holes are required.

Refer to Table 13 and Table 14 on page 38. Bore capacities can be increased beyond values shown if the coupling torque rating is reduced. Refer to the Factory. Recommended key sizes for the listed maximum bores are shown in Table 35, page 48, and Table 23, page 43.

**TABLE 29 –Flex Hub Puller Bolt Holes for Reduced Shank Diameter Hubs (in)**

Size ①	N	B.C.	Tap Size	Size ①	N	B.C.	Tap Size
1160/2160G	25.50	22.50	1.500-6 UNC	1240/2240G	41.50	36.50	2-4.5 UNC
	20.75	17.75			34.00	29.00	
1180/2180G	29.50	26.00	1.500-6 UNC	1260/2260G	45.50	40.50	2-4.5 UNC
	24.00	20.50			37.25	32.25	
1200/2200G	33.50	29.50	2-4.5 UNC	1280/2280G	49.50	44.50	2-4.5 UNC
	27.25	23.25			40.75	35.75	
1220/2220G	37.50	33.00	2-4.5 UNC	1300/2300G	53.50	48.50	2-4.5 UNC
	30.75	26.25			44.00	39.00	

# ENGINEERING DATA — LARGE FLANGED SLEEVE (Cont.)

## Standard Filleted Keyways & Chamfered Keys

It is general practice in industry to supply coupling hubs with minimum fillet radii in the keyway corners to permit the use of standard commercial keys without chamfered edges. Regal Rexnord will cut filleted keyways when specified in accordance with the established industry standards as shown in **Table 31** at no extra charge.

**TABLE 30 – Standard Filleted Keyways & Chamfered Keys (in)**

Normal Bore		Key		Hub Keyway			
Over	Thru	Size (Nominal)	45° Chamfer Suggested	Width		Depth ① + .010 to + .020	Fillet Radii
4.000	4.500	1.000 x 1.000	0.078	1.000	+ .0030 - .0000	0.500	0.062
4.500	5.500	1.250 x 1.250	0.156	1.250	+ .0035	0.625	0.125
5.500	6.500	1.500 x 1.500	0.156	1.500	- .0000	0.750	0.125
6.500	7.500	1.750 x 1.500	0.156	1.750	+ .0040	0.750	0.125
7.500	9.000	2.000 x 1.500	0.156	2.000	- .0000	0.750	0.125
9.000	11.000	2.500 x 1.750	0.156	2.500	+ .0045	0.875	0.125
11.000	13.000	3.000 x 2.000	0.219	3.000	- .0000	1.000	0.188
13.000	15.000	3.500 x 2.500	0.219	3.500	+ .0050	1.250	0.188
15.000	18.000	4.000 x 3.000	0.281	4.000	- .0000	1.500	0.250
18.000	22.000	5.000 x 3.500	0.281	5.000	+ .0060	1.750	0.250
22.000	26.000	6.000 x 4.000	0.406	6.000	- .0000	2.000	0.375
26.000	30.000	7.000 x 5.000	0.406	7.000	+ .0060 - .0000	2.500	0.375

① Shallow keyway depths must be equal or exceed 2/3 of the full keyway depth of the square keys shown above.

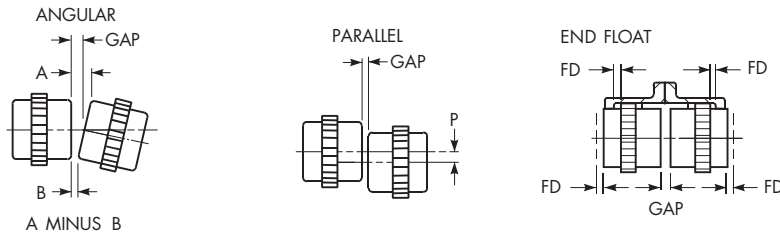
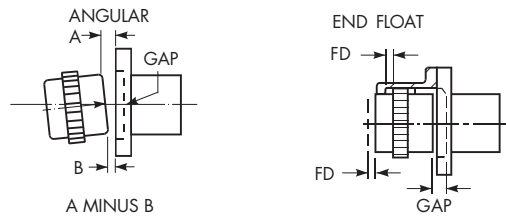

**TABLE 31 – Misalignment & End Float – Double Engagement Couplings**

Size	Angular Misalignment Limits						Parallel Misalignment Limits						End Float		
	Installation		Operating ②		Static ②		Installation		Operating ②		Static ②		Std FD (Min)	Normal GAP +/-10%	Physical Limit (Min) (2) FD +GAP
	A Minus B (in)	Degrees per Mesh	A Minus B (in)	Degrees per Mesh	A Minus B (in)	Degrees per Mesh	P (in)	Degrees per Mesh	P (in)	Degrees per Mesh	P (in)	Degrees per Mesh			
1080/2080	0.032	1/16°	0.190	3/8°	0.380	3/4°	0.016	1/16°	0.097	3/8°	0.193	3/4°	0.170	0.375	0.715
1090/2090	0.036	1/16°	0.216	3/8°	0.432	3/4°	0.017	1/16°	0.104	3/8°	0.206	3/4°	0.248	0.500	0.996
1100/2100	0.040	1/16°	0.242	3/8°	0.484	3/4°	0.019	1/16°	0.117	3/8°	0.234	3/4°	0.248	0.500	0.996
1110/2110	0.045	1/16°	0.268	3/8°	0.537	3/4°	0.022	1/16°	0.130	3/8°	0.259	3/4°	0.248	0.500	0.996
1120/2120	0.049	1/16°	0.295	3/8°	0.590	3/4°	0.023	1/16°	0.138	3/8°	0.277	3/4°	0.248	0.500	0.996
1130/2130	0.052	1/16°	0.314	3/8°	0.628	3/4°	0.024	1/16°	0.142	3/8°	0.285	3/4°	0.345	0.750	1.440
1140/2140	0.057	1/16°	0.340	3/8°	0.681	3/4°	0.025	1/16°	0.150	3/8°	0.299	3/4°	0.345	0.750	1.440
1150/2150	0.061	1/16°	0.367	3/8°	0.733	3/4°	0.027	1/16°	0.164	3/8°	0.328	3/4°	0.345	0.750	1.440
1160/2160	0.063	1/16°	0.380	3/8°	0.759	3/4°	0.028	1/16°	0.166	3/8°	0.331	3/4°	0.460	1.000	1.920
1180/2180	0.072	1/16°	0.432	3/8°	0.864	3/4°	0.029	1/16°	0.172	3/8°	0.344	3/4°	0.460	1.000	1.920
1200/2200	0.080	1/16°	0.478	3/8°	0.956	3/4°	0.035	1/16°	0.208	3/8°	0.416	3/4°	0.460	1.000	1.920
1220/2220	0.087	1/16°	0.524	3/8°	1.047	3/4°	0.039	1/16°	0.231	3/8°	0.462	3/4°	0.460	1.000	1.920
1240/2240	0.097	1/16°	0.582	3/8°	1.165	3/4°	0.042	1/16°	0.252	3/8°	0.504	3/4°	0.460	1.000	1.920
1260/2260	0.106	1/16°	0.635	3/8°	1.278	3/4°	0.046	1/16°	0.273	3/8°	0.547	3/4°	0.460	1.000	1.920
1280/2280	0.115	1/16°	0.687	3/8°	1.374	3/4°	0.047	1/16°	0.281	3/8°	0.563	3/4°	0.460	1.000	1.920
1300/2300	0.123	1/16°	0.740	3/8°	1.479	3/4°	0.048	1/16°	0.290	3/8°	0.579	3/4°	0.460	1.000	1.920

② These maximum operating alignment limits are each based on 3/8° per flex half coupling. Combined values of parallel and angular misalignment should not exceed 3/8°. Type GL slide couplings are limited to 1/4° per flex half. Application requirements in excess of these values should be referred to the Factory for review.

# ENGINEERING DATA — LARGE FLANGED SLEEVE (Cont.)



**TABLE 32 – Misalignment & End Float – Single Engagement Couplings**

Size	Angular Misalignment Limits ①						End Float			
	Installation		Operating		Static		Std FD (Min)	Normal Shaft GAP	Normal Face GAP (X)	Physical Limit (Min) FD + GAP
	A Minus B (in)	Degrees per Mesh	A Minus B (in)	Degrees per Mesh	A Minus B (in)	Degrees per Mesh				
1080/2080	0.032	1/8 °	0.095	3/8°	0.190	3/4°	0.180	0.500	0.180	0.680
1090/2090	0.036	1/8 °	0.108	3/8°	0.216	3/4°	0.258	0.562	0.242	0.820
1100/2100	0.040	1/8 °	0.121	3/8°	0.242	3/4°	0.255	0.625	0.245	0.880
1110/2110	0.045	1/8 °	0.134	3/8°	0.268	3/4°	0.255	0.625	0.245	0.880
1120/2120	0.049	1/8 °	0.147	3/8°	0.295	3/4°	0.255	0.625	0.245	0.880
1130/2130	0.052	1/8 °	0.157	3/8°	0.314	3/4°	0.340	0.750	0.370	1.090
1140/2140	0.057	1/8 °	0.170	3/8°	0.340	3/4°	0.340	0.750	0.370	1.090
1150/2150	0.061	1/8 °	0.183	3/8°	0.367	3/4°	0.340	0.750	0.370	1.090
1160/2160	0.063	1/8 °	0.190	3/8°	0.380	3/4°	0.450	1.000	0.500	1.450
1180/2180	0.072	1/8 °	0.216	3/8°	0.432	3/4°	0.450	1.000	0.500	1.450
1200/2200	0.080	1/8 °	0.239	3/8°	0.478	3/4°	0.450	1.000	0.500	1.450
1220/2220	0.087	1/8 °	0.262	3/8°	0.524	3/4°	0.450	1.125	0.500	1.575
1240/2240	0.097	1/8 °	0.291	3/8°	0.582	3/4°	0.450	1.125	0.500	1.575
1260/2260	0.106	1/8 °	0.317	3/8°	0.635	3/4°	0.450	1.125	0.500	1.575
1280/2280	0.115	1/8 °	0.344	3/8°	0.687	3/4°	0.445	1.125	0.505	1.575
1300/2300	0.123	1/8 °	0.370	3/8°	0.740	3/4°	0.445	1.125	0.505	1.575

① Do not use single engagement couplings to compensate for parallel offset misalignment.

# ENGINEERING DATA — ALL GEAR COUPLINGS

**TABLE 33 – Recommended Commercial Keys for Bores with One Key (in/mm)**

Inches (Per ANSI B17.1 Standard)

Shaft Diameter		Key	Shaft Diameter		Key	Shaft Diameter		Key	Shaft Diameter		Key
Over	Through		Over	Through		Over	Through		Over	Through	
0.438	0.562	0.125 x 0.125	1.750	2.250	0.500 x 0.500	4.500	5.500	1.250 x 1.250	11.000	13.000	3.000 x 2.000
0.562	0.875	0.188 x 0.188	2.250	2.750	0.625 x 0.625	5.500	6.500	1.500 x 1.500	13.000	15.000	3.500 x 2.500
0.875	1.250	0.250 x 0.250	2.750	3.250	0.750 x 0.750	6.500	7.500	1.750 x 1.500	15.000	18.000	4.000 x 3.000
1.250	1.375	0.312 x 0.312	3.250	3.750	0.875 x 0.875	7.500	9.000	2.000 x 1.500	18.000	22.000	5.000 x 3.500
1.375	1.750	0.375 x 0.375	3.750	4.500	1.000 x 1.000	9.000	11.000	2.500 x 1.750	–	–	–

Millimeters (Per ISO R773 Standard)

Shaft Diameter		Key	Shaft Diameter		Key	Shaft Diameter		Key	Shaft Diameter		Key
Over	Through		Over	Through		Over	Through		Over	Through	
6	8	2 x 2	38	44	12 x 8	95	110	28 x 16	260	290	63 x 32
8	10	3 x 3	44	50	14 x 9	110	130	32 x 18	290	330	70 x 36
10	12	4 x 4	50	58	16 x 10	130	150	36 x 20	330	380	80 x 40
12	17	5 x 5	58	65	18 x 11	150	170	40 x 22	380	440	90 x 45
17	22	6 x 6	65	75	20 x 12	170	200	45 x 25	440	500	100 x 50
22	30	8 x 7	75	85	22 x 14	200	230	50 x 28	–	–	–
30	38	10 x 8	85	95	25 x 14	230	260	56 x 32	–	–	–

TABLE 34 –Recommended Hub Inch Bores for Clearance & Interference Fit

Shaft Dia	Clearance Fit ②		Interference Fit ①		Shaft Dia	Clearance Fit ②		Interference Fit ①		Shaft Dia	Interference Fit ①				
	Hub Bore	Clearance	Hub Bore	Interference		Hub Bore	Clearance	Hub Bore	Interference		Shaft Dia	Hub Bore	Interference		
+ .0000	+ .0010	.0000	+ .0005	.0000	+ .0000	+ .0015	.0000	+ .0015	.0010	+ .0000	+ .0015	.0015	+ .000	+ .003	.0110
-.0005	-.0000	.0015	-.0000	.0010	-.0010	-.0000	.0025	-.0000	.0035	-.0010	-.0000	.0040	-.002	-.000	.0160
0.5000	0.5000		0.4990		4.0625	4.0625		4.0590		6.7500	6.7460		26.500	26.4840	
0.5625	0.5625		0.5615		4.1250	4.1250		4.1215		7.0000	6.9960		27.000	26.9840	
0.6250	0.6250		0.6240		4.1875	4.1875		4.1840		+ .0000	+ .0020	.0020	27.500	27.4840	
0.6875	0.6875		0.6865		4.2500	4.2500		4.2465		-.0010	-.0000	.0050	28.000	27.9840	
0.7500	0.7500		0.7490		4.3125	4.3125		4.3090		7.250	7.2450		28.500	28.4830	.0120
0.8125	0.8125		0.8115		4.3750	4.3750		4.3715		7.500	7.4950		29.000	28.9830	.0170
0.8750	0.8750		0.8740		4.4375	4.4375		4.4340		7.750	7.7450		29.500	29.4830	
0.9375	0.9375		0.9365		4.5000	4.5000		4.4965		8.000	7.9950		30.000	29.9830	
1.0000	1.0000		0.9990		4.5625	4.5625		4.5590		8.250	8.2445	.0025	+ .000	+ .004	.0110
1.0625	1.0625		1.0615		4.6250	4.6250		4.6215		8.500	8.4945	.0055	-.003	-.000	.0180
1.1250	1.1250		1.1240		4.6875	4.6875		4.6840		8.750	8.7445		30.500	30.4820	
1.1875	1.1875		1.1865		4.7500	4.7500		4.7465		9.000	8.9945		31.000	30.9820	
1.2500	1.2500		1.2490		4.8125	4.8125		4.8090		9.250	9.2440	.0030	31.500	31.4810	.0120
1.3125	1.3125		1.3115		4.8750	4.8750		4.8715		9.500	9.4940	.0060	32.000	31.9810	.0190
1.3750	1.3750		1.3740		4.9375	4.9375		4.9340		9.750	9.7440		32.500	32.4810	
1.4375	1.4375		1.4365		5.0000	5.0000		4.9965		10.000	9.9940		33.000	32.9810	
1.5000	1.5000		1.4990		5.0625	5.0625		5.0585	.0015	10.250	10.2435	.0035	33.500	33.4800	.0130
+ .0000	+ .0010	.0000	+ .0005	.0000	5.1250	5.1250		5.1210	.0040	10.500	10.4935	.0065	34.000	33.9800	.0200
-.0010	-.0000	.0020	-.0000	.0015	5.1875	5.1875		5.1835		10.750	10.7435		34.500	34.4800	
1.5625	1.5625		1.5610		5.2500	5.2500		5.2460		11.000	10.9935		35.000	34.9790	
1.6250	1.6250		1.6235		5.3125	5.3125		5.3085		11.250	11.2430	.0040	+ .000	+ .004	.0140
1.6875	1.6875		1.6860		5.3750	5.3750		5.3710		11.500	11.4930	.0070	-.003	-.000	.0210
1.7500	1.7500		1.7485		5.4375	5.4375		5.4335		11.750	11.7430		35.500	35.4790	
1.8125	1.8125		1.8110		5.5000	5.5000		5.4960		12.000	11.9930		36.000	36.9790	
1.8750	1.8750		1.8735		5.5625	5.5625		5.5585		12.500	12.4925	.0045	36.500	36.4790	
1.9375	1.9375		1.9360		5.6250	5.6250		5.6210		13.000	12.9925	.0075	37.000	36.9790	
2.0000	2.0000		1.9985		5.6875	5.6875		5.6835		13.500	13.4920	.0050	+ .000	+ .004	.0150
+ .0000	+ .0015	.0000	+ .0005	.0000	5.7500	5.7500		5.7460		14.000	13.9920	.0080	-.003	-.000	.0220
-.0010	-.0000	.0025	-.0000	.0015	5.8125	5.8125		5.8085		14.500	14.4915	.0055	37.500	37.4780	
2.0625	2.0625		2.0610		5.8750	5.8750		5.8710		15.000	14.9915	.0085	38.000	37.9780	
2.1250	2.1250		2.1235		5.9375	5.9375		5.9335		+ .000	+ .0025	.0055	38.500	38.4780	
2.1875	2.1875		2.1860		6.0000	6.0000		5.9960		-.001	-.0000	.0090	39.000	38.9780	
+ .0000	+ .0015	.0000	+ .0010	.0000	6.0625	6.2500		6.2460		15.500	15.4910		39.500	39.4970	.0160
-.0010	-.0000	.0025	-.0000	.0020	6.5000	6.5000		6.4960		16.000	15.9910		40.000	39.9770	.0230
2.2500	2.2500		2.2480							16.500	16.4905	.0060	+ .000	+ .005	.0150
2.3125	2.3125		2.3105							17.000	16.9905	.0095	-.004	-.000	.0240
2.3750	2.3750		2.3730							17.500	17.4895	.0070	40.500	40.4760	
2.4375	2.4375		2.4355							18.000	17.9895	.0105	41.000	40.9760	
2.5000	2.5000		2.4980							18.500	18.4890	.0075	41.500	41.4760	
2.5625	2.5625		2.5605							19.000	18.9890	.0110	42.000	41.9760	
2.6250	2.6250		2.6230							19.500	19.4880	.0085	42.500	42.4750	.0160
2.6875	2.6875		2.6855							20.000	19.9880	.0120	43.000	42.9750	.0250
2.7500	2.7500		2.7480							+ .000	+ .003	.0080	43.500	43.4750	
2.8125	2.8125		2.8105							-.002	-.000	.0130	44.000	43.9750	
2.8750	2.8750		2.8730							20.500	20.4870		44.500	44.4740	.0170
2.9375	2.9375		2.9355							21.000	20.9870		45.000	44.9740	.0260
3.0000	3.0000		2.9980							21.500	21.4870		45.500	45.4740	
+ .0000	+ .0015	.0000	+ .0010	.0005						22.000	21.9870		46.000	45.9740	
-.0010	-.0000	.0025	-.0000	.0025						22.500	22.4860	.0090	46.500	46.4730	.0180
3.0625	3.0625		3.0600							23.000	22.9860	.0140	47.000	46.9730	.0270
3.1250	3.1250		3.1225							23.500	23.4860		47.500	47.4730	
3.1875	3.1875		3.1850							24.000	23.9860		48.000	47.9730	
3.2500	3.2500		3.2475							+ .000	+ .003	.0100	48.500	48.4720	.0190
3.3125	3.3125		3.3100							-.002	-.000	.0150	49.000	48.9720	.0280
3.3750	3.3750		3.3725							24.500	24.4850		49.500	49.4720	
3.4375	3.4375		3.4350							25.000	24.9850		50.000	49.9720	
3.5000	3.5000		3.4975							25.500	25.4850		50.500	50.4710	.0200
3.5625	3.5625		3.5600							26.000	25.9850		51.000	50.9710	.0290
3.6250	3.6250		3.6225										51.500	51.4710	
3.6875	3.6875		3.6850										52.000	51.9710	
3.7500	3.7500		3.7475										52.500	52.4700	.0210
3.8125	3.8125		3.8100										53.000	52.9700	.0300
3.8750	3.8750		3.8725										53.500	53.4700	
3.9375	3.9375		3.9350										54.000	53.9700	
4.0000	4.0000		3.9975												

① Based on an average interference fit of 0.0005" per inch (0.5 mm per m) of shaft diameter. Tolerances and fits comply with, or are within AGMA 9002 standards.

② Regal Rexnord™ gear couplings are supplied with an interference fit as a standard. Clearance fits can be provided on request.

TABLE 35 – Recommended Hub Bores for Clearance & Interference Fit on Keyed Shafting

	Shaft Diameter	Clearance Fit		Transitional Fit		Interference Fit	
		Hub Bore	Fit $\ominus$	Hub Bore	Fit $\ominus$	Hub Bore	Fit $\ominus$
>12	j6	F7	0,008	H7	-0,008	M6	-0,023
MM	0,008 / -0,003	0,016 / 0,034	0,037	0,000 / 0,018	0,021	-0,015 / -0,004	-0,001
12	12,008 / 11,997	12,016 / 12,034	↓	12,000 / 12,018	↓	11,985 / 11,996	↓
14	14,008 / 13,997	14,016 / 14,034	↓	14,000 / 14,018	↓	13,985 / 13,996	↓
16	16,008 / 15,997	16,016 / 16,034	↓	16,000 / 16,018	↓	15,985 / 15,996	↓
18	18,008 / 17,997	18,016 / 18,034	↓	18,000 / 18,018	↓	17,985 / 17,996	↓
>18	j6	F7	0,011	H7	-0,009	M6	-0,026
MM	0,009 / -0,004	0,020 / 0,041	0,045	0,000 / 0,021	0,025	-0,017 / -0,004	0,000
19	19,009 / 18,996	19,020 / 19,041	↓	19,000 / 19,021	↓	18,983 / 18,996	↓
20	20,009 / 19,996	20,020 / 20,041	↓	20,000 / 20,021	↓	19,983 / 19,996	↓
22	22,009 / 21,996	22,020 / 22,041	↓	22,000 / 22,021	↓	21,983 / 21,996	↓
24	24,009 / 23,996	24,020 / 24,041	↓	24,000 / 24,021	↓	23,983 / 23,996	↓
25	25,009 / 24,996	25,020 / 25,041	↓	25,000 / 25,021	↓	24,983 / 24,996	↓
28	28,009 / 27,996	28,020 / 28,041	↓	28,000 / 28,021	↓	27,983 / 27,996	↓
30	30,009 / 29,996	30,020 / 30,041	↓	30,000 / 30,021	↓	29,983 / 29,996	↓
>30	k6	F7	0,007	H7	-0,018	K6	-0,031
MM	0,018 / 0,002	0,025 / 0,050	0,048	0,000 / 0,025	0,023	-0,013 / 0,003	0,001
32	32,018 / 32,002	32,025 / 32,050	↓	32,000 / 32,025	↓	31,987 / 32,003	↓
35	35,018 / 35,002	35,025 / 35,050	↓	35,000 / 35,025	↓	34,987 / 35,003	↓
38	38,018 / 38,002	38,025 / 38,050	↓	38,000 / 38,025	↓	37,987 / 38,003	↓
40	40,018 / 40,002	40,025 / 40,050	↓	40,000 / 40,025	↓	39,987 / 40,003	↓
42	42,018 / 42,002	42,025 / 42,050	↓	42,000 / 42,025	↓	41,987 / 42,003	↓
45	45,018 / 45,002	45,025 / 45,050	↓	45,000 / 45,025	↓	44,987 / 45,003	↓
48	48,018 / 48,002	48,025 / 48,050	↓	48,000 / 48,025	↓	47,987 / 48,003	↓
50	50,018 / 50,002	50,025 / 50,050	↓	50,000 / 50,025	↓	49,987 / 50,003	↓
>50	m6	F7	0,000	H7	-0,030	K7	-0,051
MM	0,030 / 0,011	0,030 / 0,060	0,049	0,000 / 0,030	0,019	-0,021 / 0,009	-0,002
55	55,030 / 55,011	55,030 / 55,060	↓	55,000 / 55,030	↓	54,979 / 55,009	↓
56	56,030 / 56,011	56,030 / 56,060	↓	56,000 / 56,030	↓	55,979 / 56,009	↓
60	60,030 / 60,011	60,030 / 60,060	↓	60,000 / 60,030	↓	59,979 / 60,009	↓
63	63,030 / 63,011	63,030 / 63,060	↓	63,000 / 63,030	↓	62,979 / 63,009	↓
65	65,030 / 65,011	65,030 / 65,060	↓	65,000 / 65,030	↓	64,979 / 65,009	↓
70	70,030 / 70,011	70,030 / 70,060	↓	70,000 / 70,030	↓	69,979 / 70,009	↓
71	71,030 / 71,011	71,030 / 71,060	↓	71,000 / 71,030	↓	70,979 / 71,009	↓
75	75,030 / 75,011	75,030 / 75,060	↓	75,000 / 75,030	↓	74,979 / 75,009	↓
80	80,030 / 80,011	80,030 / 80,060	↓	80,000 / 80,030	↓	79,979 / 80,009	↓
>80	m6	F7	0,001	H7	-0,035	M7	-0,070
MM	0,035 / 0,013	0,036 / 0,071	0,058	0,000 / 0,035	0,022	-0,035 / 0,000	-0,013
85	85,035 / 85,013	85,036 / 85,071	↓	85,000 / 85,035	↓	84,965 / 85,000	↓
90	90,035 / 90,013	90,036 / 90,071	↓	90,000 / 90,035	↓	89,965 / 90,000	↓
95	95,035 / 95,013	95,036 / 95,071	↓	95,000 / 95,035	↓	94,965 / 95,000	↓
100	100,035 / 100,013	100,036 / 100,071	↓	100,000 / 100,035	↓	99,965 / 100,000	↓
>100	m6	F7	0,003	H7	-0,040	P7	-0,094
MM	0,035 / 0,013	0,036 / 0,071	0,068	0,000 / 0,035	0,025	-0,059 / -0,024	-0,037
110	110,035 / 110,013	110,036 / 110,071	↓	110,000 / 110,035	↓	109,941 / 109,976	↓
120	120,035 / 120,013	120,036 / 120,071	↓	120,000 / 120,035	↓	119,941 / 119,976	↓
>120	m6	F7	0,003	H7	-0,040	P7	-0,108
MM	0,040 / 0,015	0,043 / 0,083	0,068	0,000 / 0,040	0,025	-0,068 / -0,028	-0,043
125	125,040 / 125,015	125,043 / 125,083	↓	125,000 / 125,040	↓	124,932 / 124,972	↓
130	130,040 / 130,015	130,043 / 130,083	↓	130,000 / 130,040	↓	129,932 / 129,972	↓
140	140,040 / 140,015	140,043 / 140,083	↓	140,000 / 140,040	↓	139,932 / 139,972	↓
150	150,040 / 150,015	150,043 / 150,083	↓	150,000 / 150,040	↓	149,932 / 149,972	↓
160	160,040 / 160,015	160,043 / 160,083	↓	160,000 / 160,040	↓	159,932 / 159,972	↓
170	170,040 / 170,015	170,043 / 170,083	↓	170,000 / 170,040	↓	169,932 / 169,972	↓
180	180,040 / 180,015	180,043 / 180,083	↓	180,000 / 180,040	↓	179,932 / 179,972	↓

	Shaft Diameter	Clearance Fit		Transitional Fit		Interference Fit	
		Hub Bore	Fit $\ominus$	Hub Bore	Fit $\ominus$	Hub Bore	Fit $\ominus$
>180	m6	F7	0,004	H7	-0,046	P7	-0,125
MM	0,046 / 0,017	0,050 / 0,096	0,079	0,000 / 0,046	0,029	-0,079 / -0,033	-0,050
190	190,046 / 190,017	190,050 / 190,096	↓	190,000 / 190,046	↓	189,921 / 189,967	↓
200	200,046 / 190,017	200,050 / 200,096	↓	200,000 / 200,046	↓	199,921 / 199,967	↓
>200	m6	F7	0,004	H7	-0,046	R7	-0,155
MM	0,046 / 0,017	0,050 / 0,096	0,079	0,000 / 0,046	0,029	-0,109 / -0,063	-0,080
210	210,046 / 210,017	210,050 / 210,096	↓	210,000 / 210,046	↓	209,891 / 209,937	↓
220	220,046 / 220,017	220,050 / 220,096	↓	220,000 / 220,046	↓	219,891 / 219,937	↓
225	225,046 / 225,017	225,050 / 225,096	↓	225,000 / 225,046	↓	224,891 / 224,937	↓
>225	m6	F7	0,004	H7	-0,046	R7	-0,159
MM	0,046 / 0,017	0,050 / 0,096	0,079	0,000 / 0,046	0,029	-0,113 / -0,067	-0,084
230	230,046 / 230,017	230,050 / 230,096	↓	230,000 / 230,046	↓	229,887 / 229,933	↓
240	240,046 / 240,017	240,050 / 240,096	↓	240,000 / 240,046	↓	239,887 / 239,933	↓
250	250,046 / 250,017	250,050 / 250,096	↓	250,000 / 250,046	↓	249,887 / 249,933	↓
>250	m6	F7	0,004	H7	-0,052	R7	-0,178
MM	0,052 / 0,020	0,056 / 0,108	0,088	0,000 / 0,052	0,032	-0,126 / -0,074	-0,094
260	260,052 / 260,020	260,056 / 260,108	↓	260,000 / 260,052	↓	259,874 / 259,926	↓
270	270,052 / 270,020	270,056 / 270,108	↓	270,000 / 270,052	↓	269,874 / 269,926	↓
280	280,052 / 280,020	280,056 / 280,108	↓	280,000 / 280,052	↓	279,874 / 279,926	↓
>280	m6	F7	0,004	H7	-0,052	R7	-0,182
MM	0,052 / 0,020	0,056 / 0,108	0,088	0,000 / 0,052	0,032	-0,130 / -0,078	-0,098
290	290,052 / 290,020	290,056 / 290,108	↓	290,000 / 290,052	↓	289,870 / 289,922	↓
300	300,052 / 300,020	300,056 / 300,108	↓	300,000 / 300,052	↓	299,870 / 299,922	↓
310	310,052 / 310,020	310,056 / 310,108	↓	310,000 / 310,052	↓	309,870 / 309,922	↓
315	315,052 / 315,020	315,056 / 315,108	↓	315,000 / 315,052	↓	314,870 / 314,922	↓
>315	m6	F7	0,005	H7	-0,057	R7	-0,201
MM	0,057 / 0,021	0,062 / 0,119	0,098	0,000 / 0,057	0,036	-0,144 / -0,087	-0,108
320	320,057 / 320,021	320,062 / 320,119	↓	320,000 / 320,057	↓	319,856 / 319,913	↓
330	330,057 / 330,021	330,062 / 330,119	↓	330,000 / 330,057	↓	329,856 / 329,913	↓
340	340,057 / 340,021	340,062 / 340,119	↓	340,000 / 340,057	↓	339,856 / 339,913	↓
350	350,057 / 350,021	350,062 / 350,119	↓	350,000 / 350,057	↓	349,856 / 349,913	↓
355	355,057 / 355,021	355,062 / 355,119	↓	355,000 / 355,057	↓	354,856 / 354,913	↓
>355	m6	F7	0,005	H7	-0,057	R8	-0,260
MM	0,057 / 0,021	0,062 / 0,119	0,098	0,000 / 0,057	0,036	-0,203 / -0,114	-0,135
360	360,057 / 360,021	360,062 / 360,119	↓	360,000 / 360,057	↓	359,797 / 359,886	↓
370	370,057 / 370,021	370,062 / 370,119	↓	370,000 / 370,057	↓	369,797 / 369,886	↓
380	380,057 / 380,021	380,062 / 380,119	↓	380,000 / 380,057	↓	379,797 / 379,886	↓
390	390,057 / 390,021	390,062 / 390,119	↓	390,000 / 390,057	↓	389,797 / 389,886	↓
400	400,057 / 400,021	400,062 / 400,119	↓	400,000 / 400,057	↓	399,797 / 399,886	↓
>400	m6	F7	0,005	H7	-0,063	R8	-0,296
MM	0,063 / 0,023	0,068 / 0,131	0,108	0,000 / 0,063	0,040	-0,233 / -0,126	-0,149
410	410,063 / 410,023	410,068 / 410,131	↓	410,000 / 410,063	↓	409,767 / 409,874	↓
420	420,063 / 420,023	420,068 / 420,131	↓	420,000 / 420,063	↓	419,767 / 419,874	↓
430	430,063 / 430,023	430,068 / 430,131	↓	430,000 / 430,063	↓	429,767 / 429,874	↓
440	440,063 / 440,023	440,068 / 440,131	↓	440,000 / 440,063	↓	439,767 / 439,874	↓
450	450,063 / 450,023	450,068 / 450,131	↓	450,000 / 450,063	↓	449,767 / 449,874	↓
>450	m6	F7	0,005	H7	-0,063	R8	-0,292
MM	0,063 / 0,023	0,068 / 0,131	0,108	0,000 / 0,063	0,040	-0,229 / -0,132	-0,155
460	460,063 / 460,023	460,068 / 460,131	↓	460,000 / 460,063	↓	459,771 / 459,868	↓
470	470,						

# LIFELIGN™ GEAR COUPLING NOMENCLATURE

## Type G

**1010**

SIZE

**G**

### PRODUCT CLASSIFICATION

Gear — Standard Flanged Sleeve

**20**

### TYPE (Shrouded and Exposed Bolts)

G10/20 = Double Engagement (Shrouded/Exposed)  
G51/52 = Single Engagement/Floating Shaft (Shrouded/Exposed)  
GV10/20 = Vertical Double Engagement (Shrouded/Exposed)  
GV51/52 = Vertical Single Engagement/Floating Shaft (Shrouded/Exposed)  
G62 = Brakewheel Double Engagement (Exposed)  
G63 = Disc Brake Double Engagement (Exposed)  
G66 = Brakewheel Single Engagement (Exposed)  
G67 = Disc Brake Single Engagement (Exposed)  
GL20 = Slide Double Engagement (Exposed)  
GL32-1 = Slide Double Engagement Spacer (Exposed)  
GL52 = Slide Single Engagement/Floating Shaft (Exposed)  
G70 = Disconnect Inching Drives  
G72 = Disconnect (Exposed)  
G31/32 = Spacer (Shrouded/Exposed)  
G81/82 = Rigid (Shrouded/Exposed)  
GV82 = Vertical Rigid (Exposed)

## Type G

**1080**

SIZE

**G**

### PRODUCT CLASSIFICATION

Gear — Large Flanged Sleeve

**20**

### TYPE (Exposed Bolts Only)

Type G20 = Double Engagement  
Type G52 = Single Engagement/Floating Shaft  
Type GV20 = Vertical Double Engagement  
Type GV52 = Vertical Single Engagement/Floating Shaft  
Type GL20-4 = Slide Double Engagement  
Type G70 = Disconnect/Inching Drives  
Type G32 = Spacer  
Type G82 = Rigid







**FALK™**

**Regal Rexnord**

Contact us: [rexnord.com/contact](https://www.rexnord.com/contact)  
[regalrexnord.com](https://www.regalrexnord.com)

The proper selection and application of products and components, including assuring that the product is safe for its intended use, are the responsibility of the customer. To view our Application Considerations, please visit <https://www.regalrexnord.com/Application-Considerations>.

To view our Standard Terms and Conditions of Sale, please visit <https://www.regalrexnord.com/Terms-and-Conditions-of-Sale> (which may redirect to other website locations based on product family).

"Regal Rexnord" is not indicative of legal entity. Refer to product purchase documentation for the applicable legal entity. Regal Rexnord, Amerigear, Falk, Kop-Flex, Lifelign, Rexnord, and Waldron are trademarks of Regal Rexnord Corporation or one of its affiliated companies.

© 2013, 2026 Regal Rexnord Corporation, All Rights Reserved. MCC-451-110-FK-EN-US 05/26

 **RegalRexnord™**